

# Lead Screws for Guided Munitions

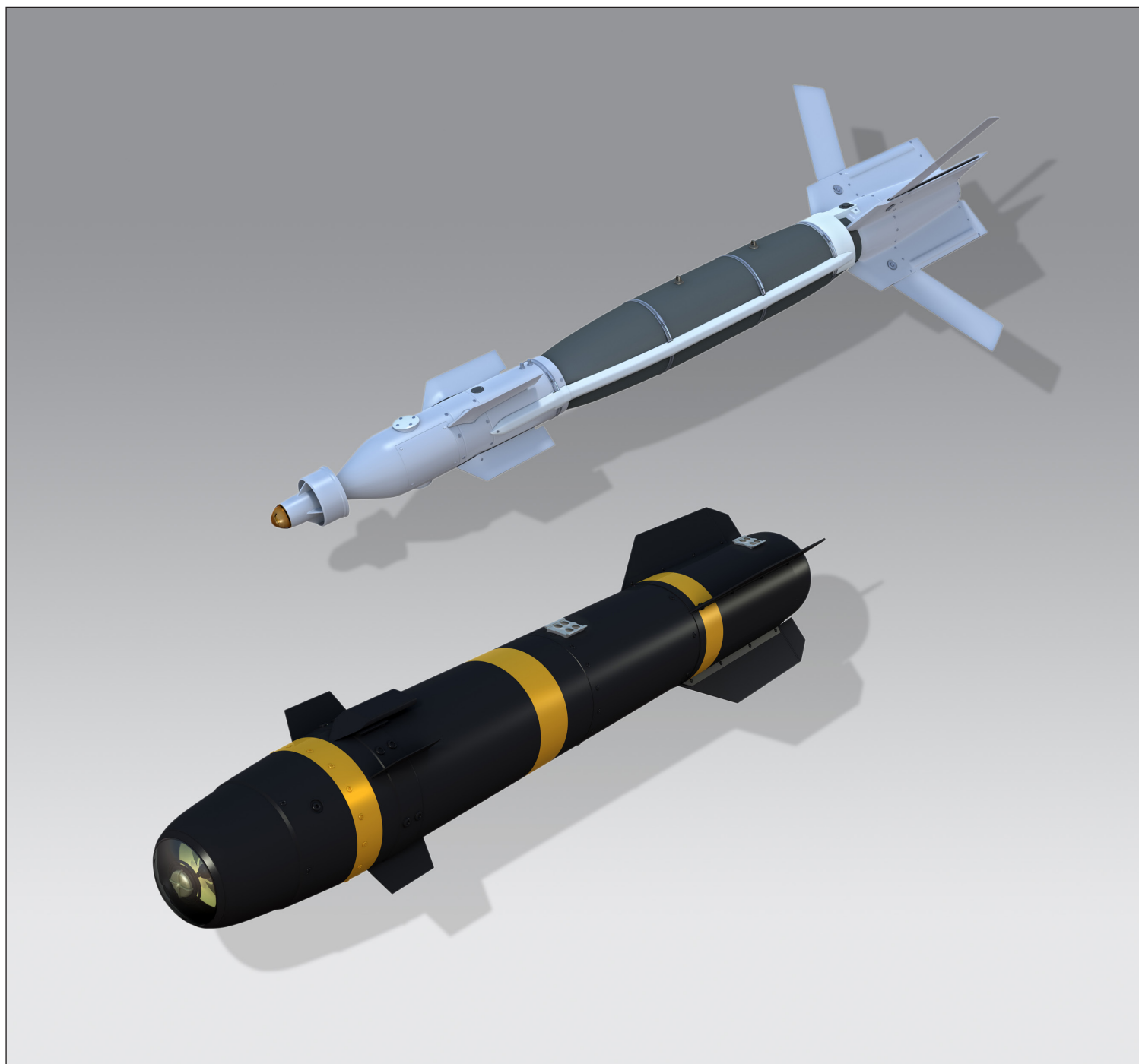

# Lead Screws for Guided Munitions

## Helix Linear Technologies Product Capabilities

### PRECISION-GUIDED MUNITIONS

PGMs, better known as “smart weapons” or “smart munitions,” are being more widely used because they are intended to precisely hit a specific target, and to minimize collateral damage. The precision of these weapons is due in part to the precise movements of the fins, wings and canards.

Because the damage effects of explosive weapons decrease with distance due to an inverse cube law, even modest improvements in accuracy (hence reduction in miss distance) enable a target to be attacked with fewer or smaller bombs. Thus, even if some guided bombs miss, fewer air crews are put at risk and the harm to civilians and the amount of collateral damage may be reduced.

The advent of precision-guided munitions resulted in the renaming of older bombs as “gravity bombs,” or “dumb bombs.”

Even in fast paced and violent conflicts, attitudes towards both ‘enemy’ and ‘friendly’ (or ‘neutral’) casualties have undergone a remarkable transformation since the days of the Second World War when, for example, a single air raid could kill tens of thousands of individuals. Increasingly, conflict scenarios involve the use of force in dense, population-heavy environments, where the negative publicity of misplaced weaponry could have profound implications for public opinion and policy.

### ENVIRONMENT

Lead screws can perform in -50° to 140°F environments when thermal expansion of the stainless steel screws and bronze or polymer nuts is incorporated into their design. High forces can also be managed by selecting an appropriately high tensile strength material for the nut. Bronze nuts are used most commonly and polymers with glass, and Kevlar can also be used along with a PTFE coating on the screw as a dry lubricant.



### PTFE COATINGS

PTFE coatings are also a lubrication solution with a long shelf life that is commonly required on applications for guided munitions. Mil-Spec greases can also be added to a lead screw assembly with a PTFE coating for increased reductions in friction.

### GUIDED MUNITIONS

Below is a list of the types of guided munitions that utilize automated wings, fins and canards to guide their flight.

- Laser-guided weapons
- Radar, infrared, IR imaging and electro-optical guided weapons
- Satellite-guided weapons
- Advanced Guided weapons
- Cannon-launched guided projectiles
- Guided small arms

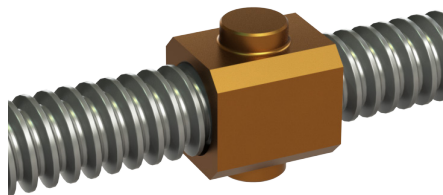

### CUSTOM DESIGNS

The design of acme nuts and lead screw nuts can easily incorporate other components and customized mounting dimensions. Threaded inserts can be added to the nut design using ultrasonic welding or using inserts welding processes. Acme nuts with trunion pins for mounting are also an ideal way to connect the nut to the wing, fin or canard assembly.

Lead screws can also be manufactured from a wide array of materials to meet the specific requirements of UAV. The following materials can be used to manufacture lead screws precisely and cost effectively.

- Titanium
- Stainless Steel
- Aluminum
- High strength Alloys
- Bronze

### MINIATURE LEAD SCREWS

Miniature lead screws can also be used in these types of applications to help fit an actuation system into small envelopes. Both metric and imperial dimensioned screw sizes are available in our miniature sizes. (Metric – 3,4,5,6mm diameter / Imperial 1/8”, 3/16”, 1/4”) Hollow lead screws can also be manufactured to reduce weight of the overall system.



### MIL-SPEC GREASES

Mil-Spec Greases can also be added to a lead screw assembly with a PTFE coating for increased reductions of friction.



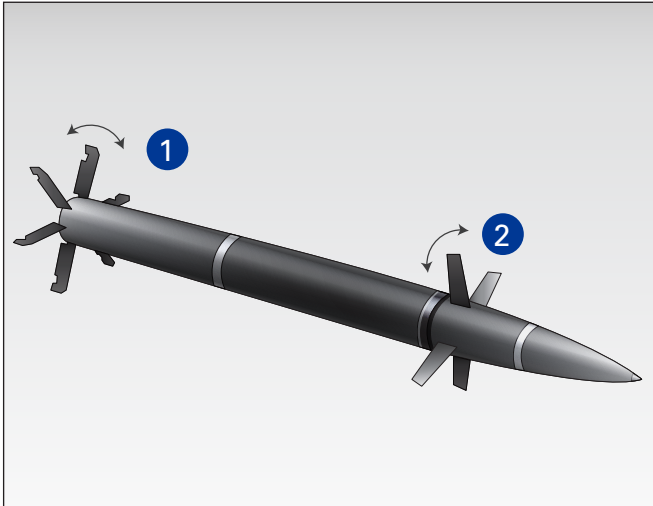

**Example 1**

- 1. Fin Actuation
- 2. Canard Actuation

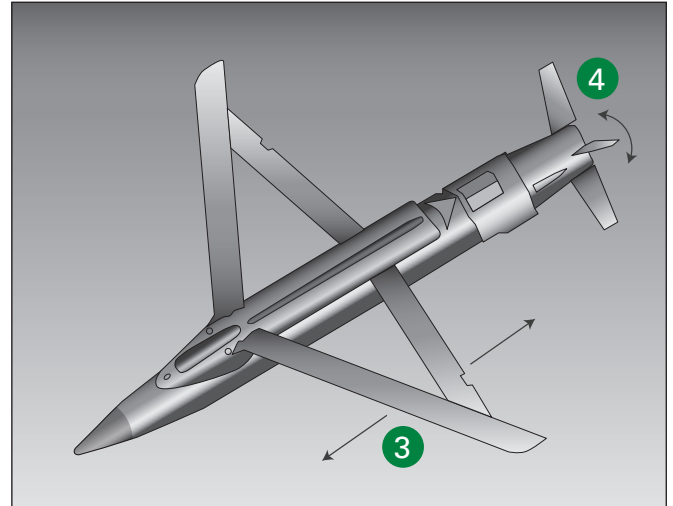

**Example 2**

- 3. Extending Wing Pack
- 4. Fin Actuation

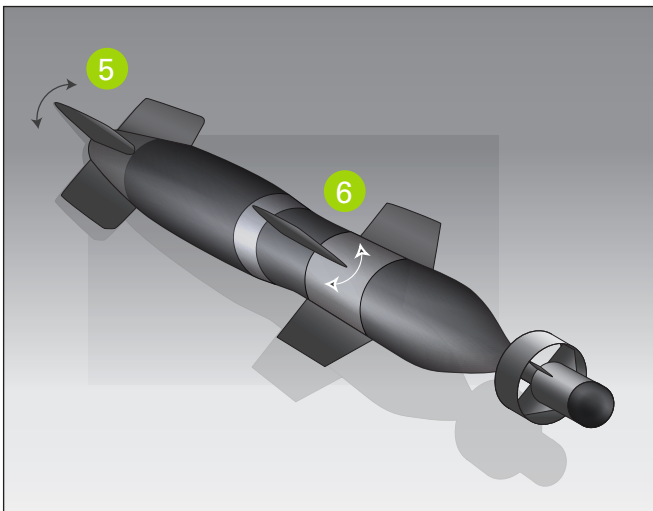

**Example 3**

- 5. Fin Actuation
- 6. Canard Actuation

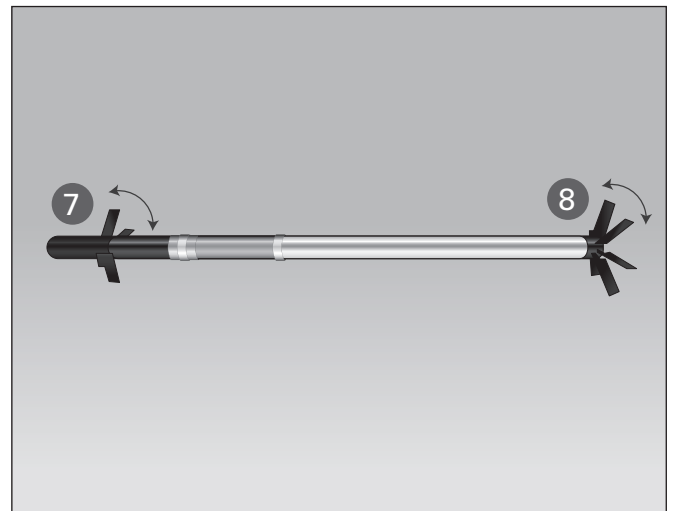

**Example 4**

- 7. Fin Actuation
- 8. Canard Actuation

# Lead Screws for Guided Munitions

## Helix Linear Technologies Product Capabilities

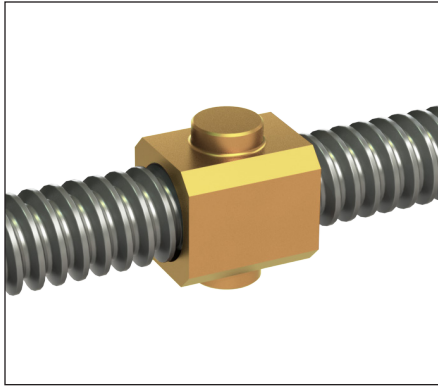

### TRUNION MOUNTED NUT

- Standard C.O.T.S. Trunion Mounted Nuts
- **Nut Material:** Bronze, High Strength Polymers, Steel, Aluminum



### MACHINING

- Bearing Journals
- Keyways
- Flats
- Hex I.D./O.D.



### MINIATURE SCREWS

- 3, 4, 5, 6mm Ø
- Fine Pitch and High Lead Screw Threads
- High Volume Production Available
- Prototype Screws Delivered in 3-4 Weeks



### TESTING AND VALIDATION

- Torque Testing and Validation
- Tensile Testing and Validation
- Efficiency Testing and Validation
- Life Testing



### PTFE COATINGS

- Dry Lubricant
- Clean Room Compatible
- Increases Efficiency

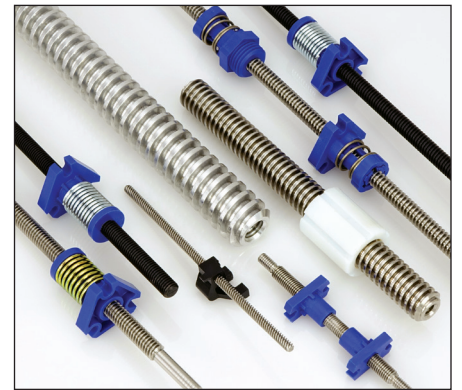

### CUSTOM SCREW SIZES

- Custom Screw Sizes Available
- 4mm - 50mm Diameter
- Quick Delivery on Prototypes

Our products make us industry leaders.  
Our people make us world class.

Christopher M. Nook, CEO  
Helix Linear Technologies, Inc.

