

MICRO PRECISION LINEAR ACTUATORS

Modular Miniature Linear Actuators

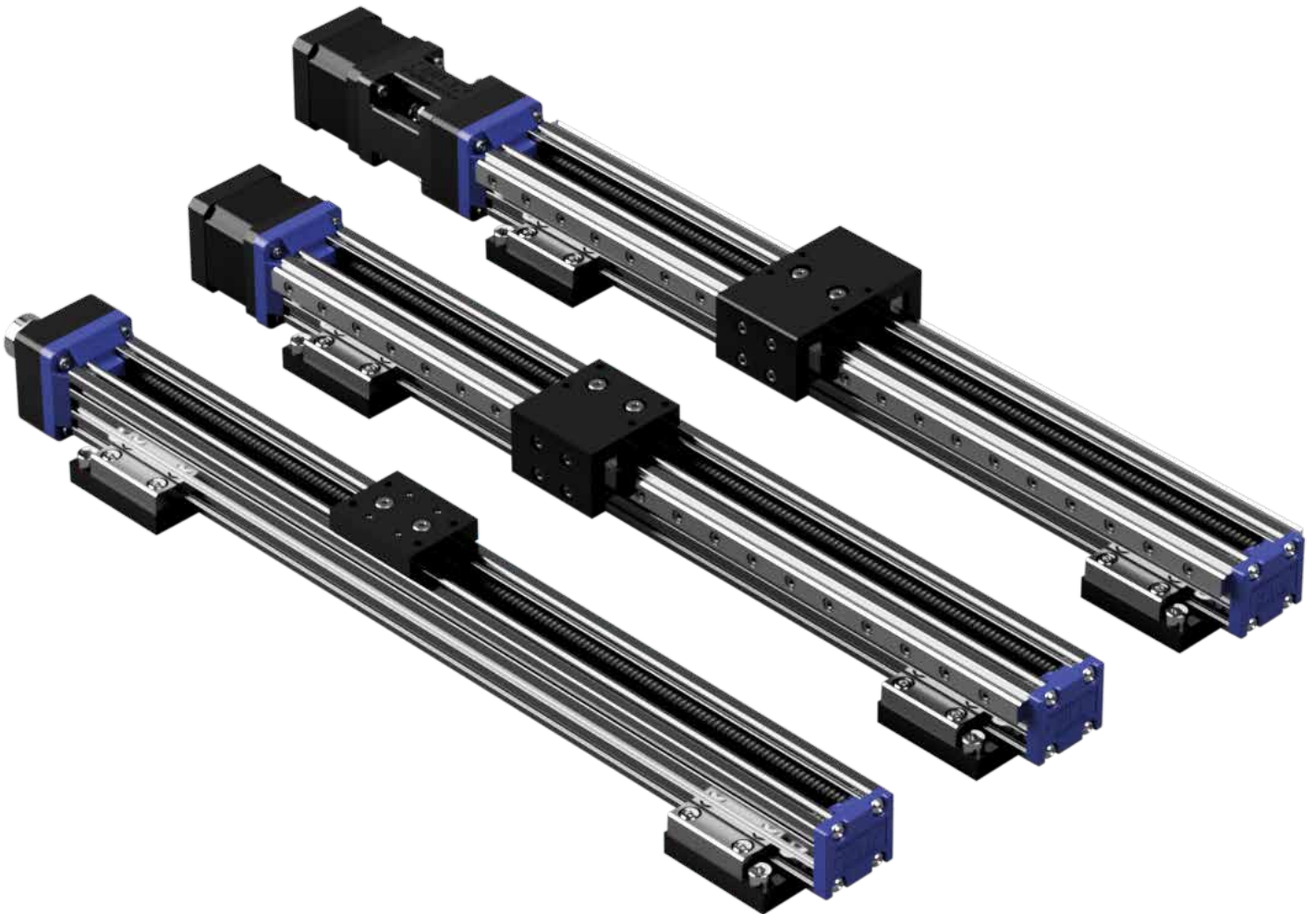



Helix Linear Technologies, Inc., Beachwood, Ohio

COMPANY

Helix is a global supplier to the Medical Device, Life Science, Security, Semiconductor, Aerospace, Electromechanical and Defense industry. Helix leads the linear motion industry by manufacturing the highest quality linear actuation solutions in the world. We focus entirely on manufacturing electromechanical actuation systems that help our customers be more productive and profitable. Our execution of innovative product designs solves real problems for our customers and builds a foundation for long term success.

HISTORY

Helix was founded in 2011 to manufacture high-quality lead screws for the growing electromechanical actuation industry. Helix's rapid growth has included the addition of linear actuator solutions to deliver integrated and or turnkey solutions.

CULTURE

Our culture is based on a team of smart, happy and competitive professionals focused on manufacturing innovative products centered on delivering precise electromechanical linear motion solutions. We are in the people business, as well as the product business. People make and sell our products and a team of smart, happy and competitive people focus on success.

OPERATIONS

Our company is built to deliver high-quality products and engineering support to solve the most demanding linear motion applications in any industry. We deliver components and subsystem solutions to high volume OEMs and custom machine builders to help secure their success.

TABLE OF CONTENTS

COMPANY OVERVIEW	2
IPA - INTEGRATED PRECISION ACTUATOR	
	4-5
CPA - COUPLED PRECISION ACTUATOR	
	6-7
SPA - SIMPLE PRECISION ACTUATOR	
	8-9
HYBRID STEPPER MOTOR SPECIFICATIONS	10
ACCESSORIES	11

IPA - Integrated Motor Linear Actuator

- Hybrid stepper motor
- Integrated profile rail
- PTFE coated screw
- Anti-backlash nut



Helix attaches the lead screw to a custom designed hybrid stepper motor with beefed-up deep groove ball bearings to maximize thrust loads and rigidity.

Motors are laser welded to the lead screw for a truly compact low cost actuator. They are available with optional encoders, connectors, and custom cables.

IPA Ordering Guide Table															
IPA	B	196	AB	17	0609	D	E 200	A	S						
Series	Linear Guide Supports	Screw Lead	Nut Type	Motor Frame Size	Actuator Length	Motor Power	Encoder	Encoder Position	Modifications						
IPA Integrated Motor and Lead Screw Actuator	A - No external rail (Square carriage)	039 - 1mm	S - Standard nut	17 NEMA 17	(mm) See page 5 for actuator length data	S - Single Stack	E 200 200 CPR	A	S - Standard						
		078 - 2mm					E 500 500 CPR								
	B - One rail - Right* one runner block ("L"-shaped carriage)	196 - 5mm				AB - Anti-backlash nut	23 NEMA 23			D - Double Stack	E 1000 1000 CPR	B	M - Modified		
		393 - 10mm									E 2000 2000 CPR				
	C - One rail - Left* one runner block ("L"-shaped carriage)	472 - 12mm				T - Triple Stack									
		999 - 25mm													
	D - Two rails, one runner block ("U"-shaped carriage)	M38 - 1.5in													

EXAMPLE PART NUMBER: IPA - B - 196 - AB - 17 - 0609 - D - E 200 - A - S

*Left and right sides are determined by looking down the assembly with the motor at the end nearest to you.

NOTE: Actuators can be customized in many ways to fit your application:

- Additional lead screw sizes available
- Custom mounting plates
- Custom carriages

IPA - INTEGRATED MOTOR LINEAR ACTUATOR

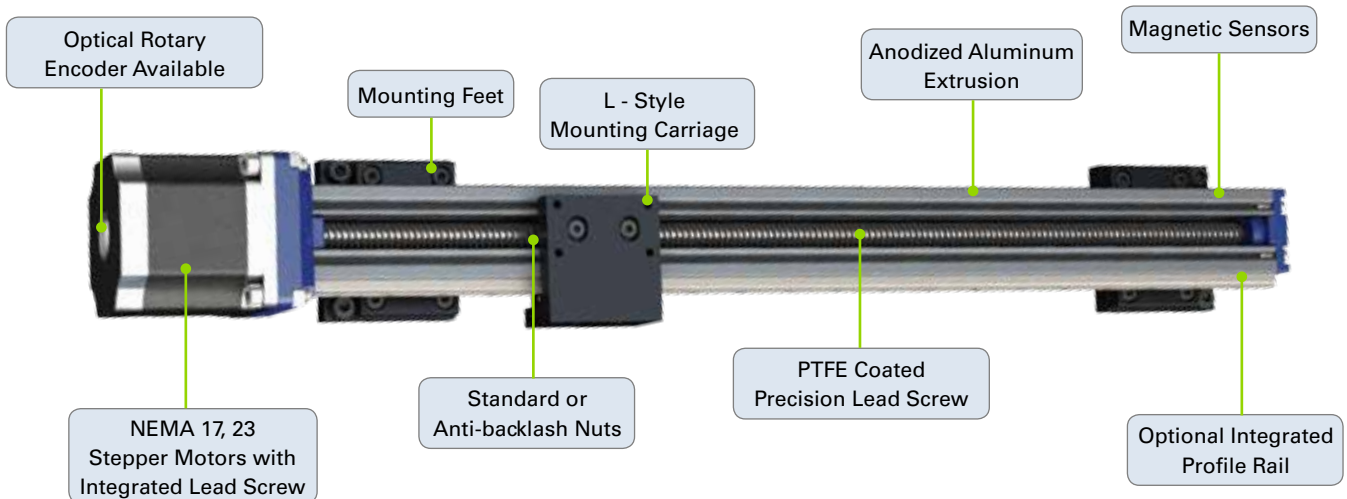

IPA DIMENSIONS

NEMA size 23 shown

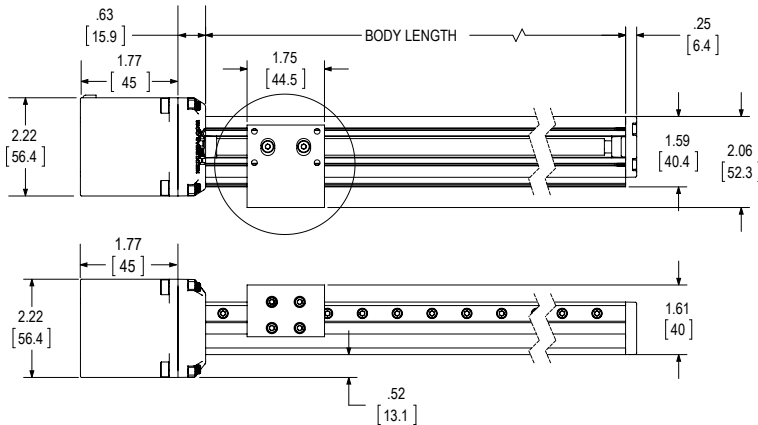

BODY LENGTH = TRAVEL + 1.75" (CARRIAGE WIDTH)
 WE RECOMMEND AN OVERTRAVEL ZONE OF 10mm
 BE ADDED TO EACH END OF YOUR DESIRED STROKE WHEN
 USING A STEPPER MOTOR.

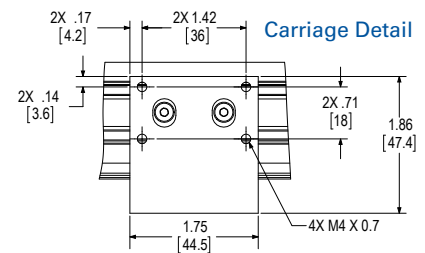

Rail and Carriage Mounting Options

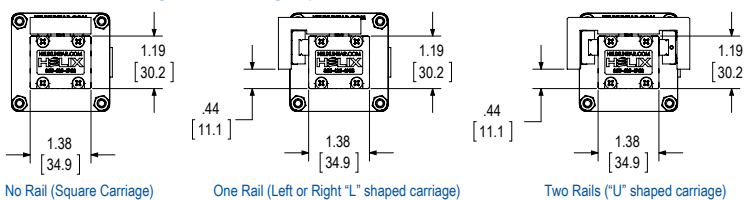

Mounting Foot

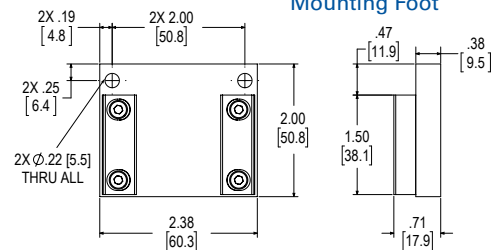

OPTIONAL COMPONENTS

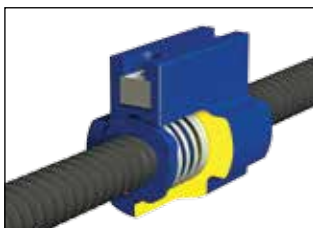

Anti-backlash lead nuts



Rotary optical encoders



Magnetic sensors

CPA - Coupled Motor Linear Actuator

- Hybrid stepper motors and stepper servo motors
- Integrated profile rail
- PTFE coated screw



Standard motor mounts allow for attachment of any NEMA frame motor. The lead screw is supported by deep groove ball bearings for years of dependable life and rigidity.

Motor mounts come complete with coupling. Custom mounts can be supplied.

CPA Ordering Guide Table

CPA	B	196	AB	14	0609	D	E 200	A	S			
Series	Linear Guide Supports	Screw Lead	Nut Type	Motor Frame Size	Actuator Length	Motor Power	Encoder	Encoder Position	Modifications			
CPA Coupled Motor and Lead Screw Actuator	A - No external rail (Square carriage)	039 - 1mm	S - Standard nut	14 NEMA 14	(mm) See page 7 for actuator length data	N - No Motor	E 200 200 CPR	A	S - Standard			
		078 - 2mm										
	B - One rail - Right* one runner block ("L"-shaped carriage)	196 - 5mm		AB - Anti- backlash nut		17 NEMA 17	D - Double Stack			E1000 1000 CPR	B	M - Modified
		393 - 10mm										
	C - One rail - Left* one runner block ("L"-shaped carriage)	472 - 12mm				23 NEMA 23	T - Triple Stack			E2000 2000 CPR		
		999 - 25mm										
	D - Two rails, one runner block ("U"-shaped carriage)	M38 - 1.5in										

EXAMPLE PART NUMBER: CPA - B - 196 - AB - 14 - 0609 - D - E 200 - A - S

*Left and right sides are determined by looking down the assembly with the motor at the end nearest to you.

NOTE: Actuators can be customized in many ways to fit your application:

- Additional lead screw sizes available
- Custom mounting plates
- Custom carriages

CPA - COUPLED MOTOR LINEAR ACTUATOR

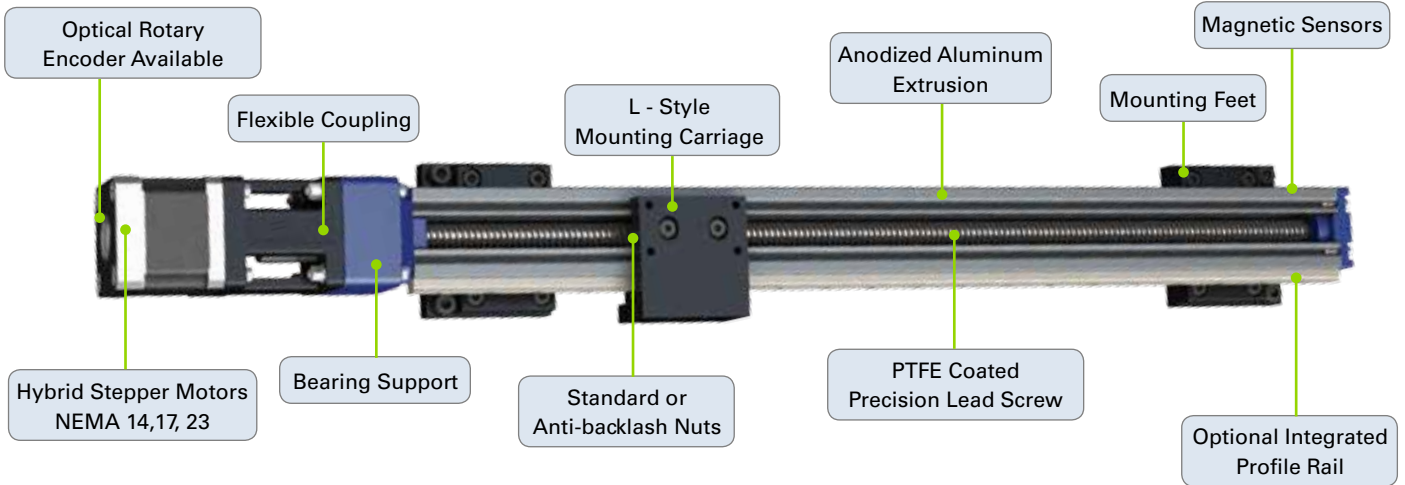

CPA DIMENSIONS

NEMA size 23 shown

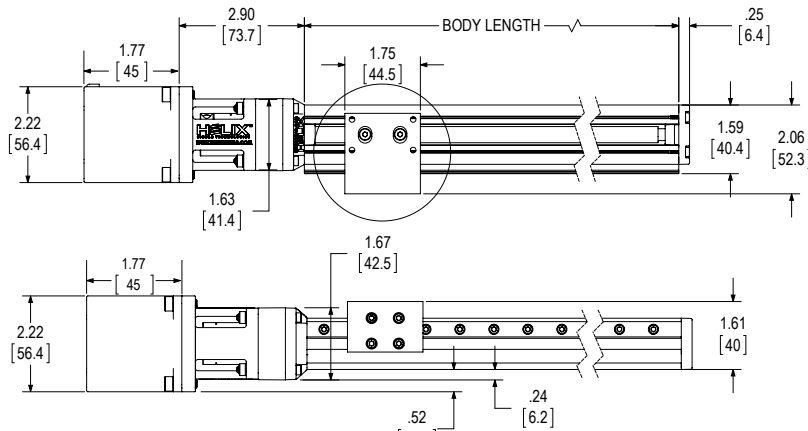

BODY LENGTH = TRAVEL + 1.75" (CARRIAGE WIDTH)
 WE RECOMMEND AN OVERTRAVEL ZONE OF 10mm
 BE ADDED TO EACH END OF YOUR DESIRED STROKE WHEN
 USING A STEPPER MOTOR.

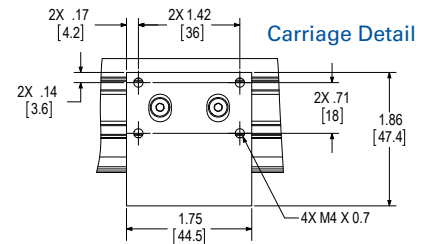

Rail and Carriage Mounting Options

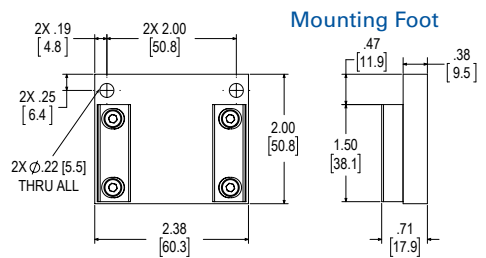
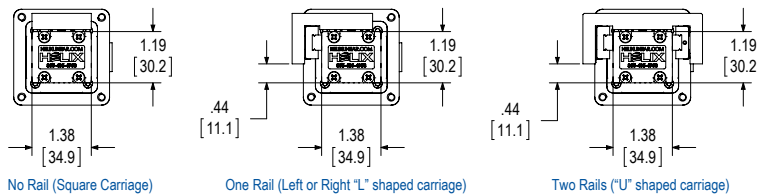

OPTIONAL COMPONENTS

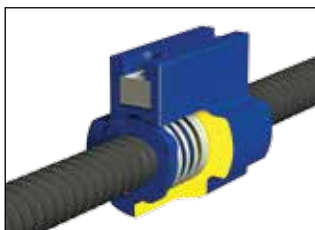

Anti-backlash lead nuts



Digital rotary encoders



Magnetic sensors

SPA - Simple Linear Actuator

- Hand, motor or belt actuated
- Integrated profile rail
- PTFE coated screw



These actuators come standard with a journal end on the lead screw, making it convenient to supply your own drive; belt, coupler or knob. There is versatile manual brake option for securely locking the actuator into position.

The lead screw is supported by end mounted deep groove ball bearings for years of dependable life and rigidity.

SPA Ordering Guide Table						
SPA	A	196	AB	00	0609	S
Series	Linear Guide Supports	Screw Lead	Nut Type	End Configuration	Actuator Length	Modifications
SPA PTFE Guide Lead Screw Actuator	A - No external rail (Square carriage)	039 - 1mm	S - Standard nut	00 - Drive Shaft	(mm) See page 9 for actuator length data	S - Standard
	B - One rail - Right* one runner block ("L"-shaped carriage)	078 - 2mm				
	C - One rail - Left* one runner block ("L"-shaped carriage)	196 - 5mm				
	D - Two rails, one runner block ("U"-shaped carriage)	393 - 10mm	AB - Anti-backlash nut	HK - Hand Knob		M - Modified
		472 - 12mm				
		999 - 25mm				
		M38 - 1.5in				

EXAMPLE PART NUMBER: SPA - B - 196 - AB - 00 - 0609 - S

**Left and right sides are determined by looking down the assembly with the motor at the end nearest to you.*

NOTE: Actuators can be customized in many ways to fit your application:

- Additional lead screw sizes available
- Custom mounting plates
- Custom carriages

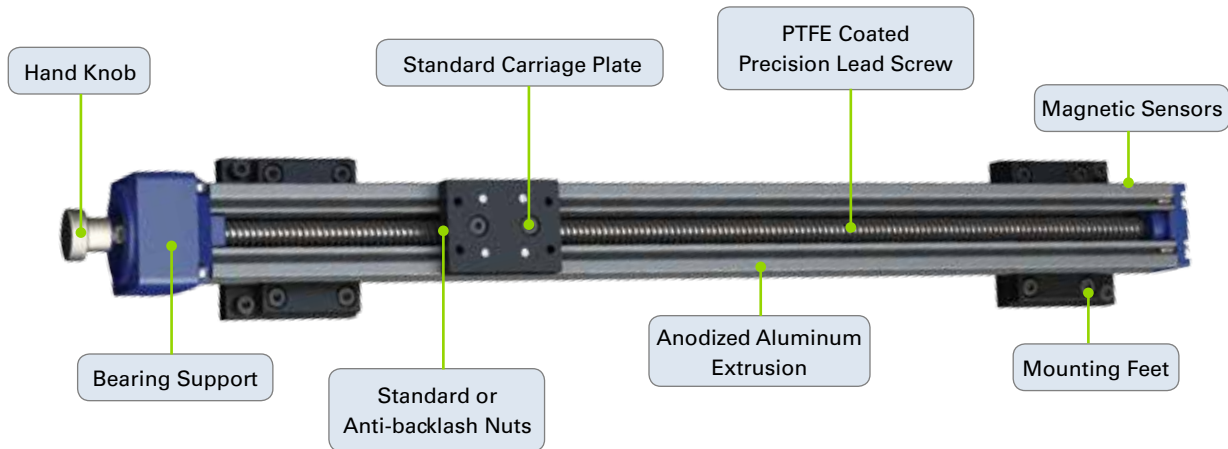

SPA DIMENSIONS

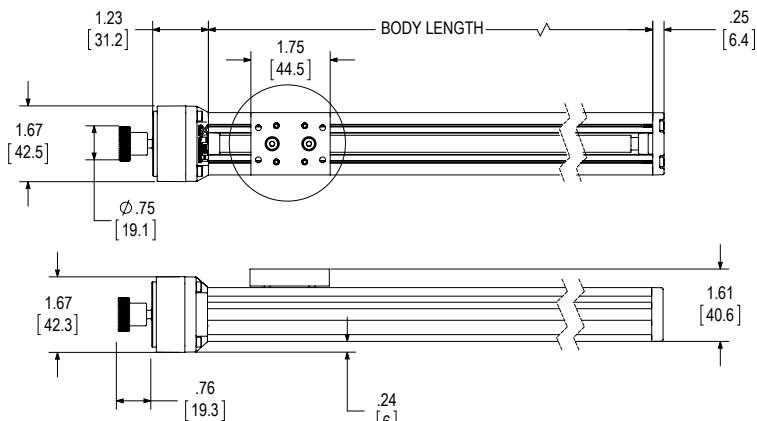

BODY LENGTH = TRAVEL + 1.75" (CARRIAGE WIDTH)
 WE RECOMMEND AN OVERTRAVEL ZONE OF 10mm
 BE ADDED TO EACH END OF YOUR DESIRED STROKE WHEN
 USING A STEPPER MOTOR.

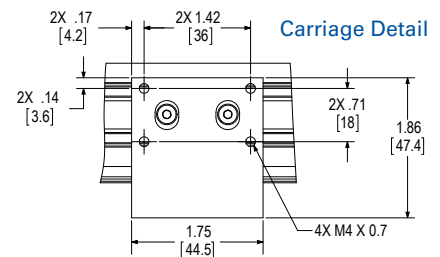

Rail and Carriage Mounting Options

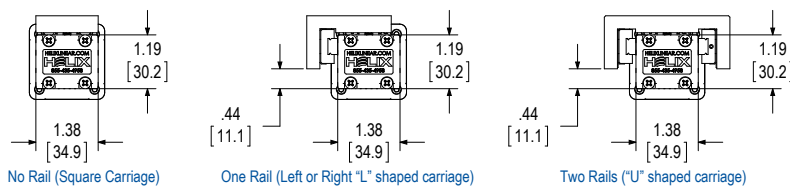

Mounting Foot

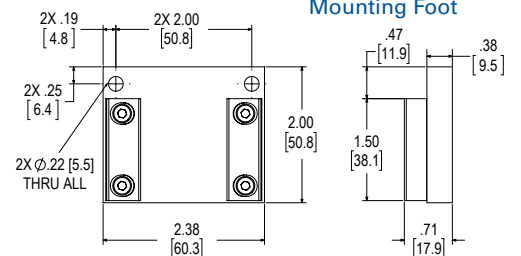

OPTIONAL COMPONENTS

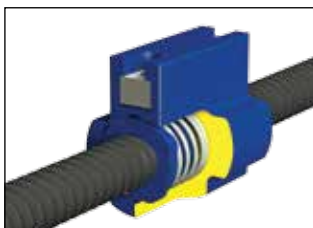

Anti-backlash lead nuts



Linear actuator carriage



Magnetic sensors

PROFILE RAIL SPECIFICATIONS

High Load and High Moment Capacity

The HMR Miniature Linear Guide series is designed using two rows of recirculating balls. The design uses a Gothic profile with a 45° contact angle to achieve equal load capacity in all directions. Within the restriction of limited space, larger stainless steel balls are used to enhance the load and torsion resistance capacity.

Helix linear guides (indicated with the thick black line to the right) provide greater surface contact as compared to competing products (indicated with the thin green-dotted line at right) when comparing same widths rails.

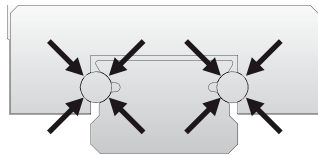

Lubrication Storage Design

Lubricant injection holes are featured at both ends of the runner block. As the balls circulate during movement of the block, the stainless steel balls carry lubrication oil to the raceway, thus efficiently lubricating the balls and the oil raceway, and achieving long-term, maintenance-free linear motion. This design also provides superb lubricating ability for short stroke movement. A newly-invented embedded lubrication pad design provides a selection of options for machine design.

(3M /W, 5M /W, 7M /W, 9M /W, 12M /W, 15M /W)

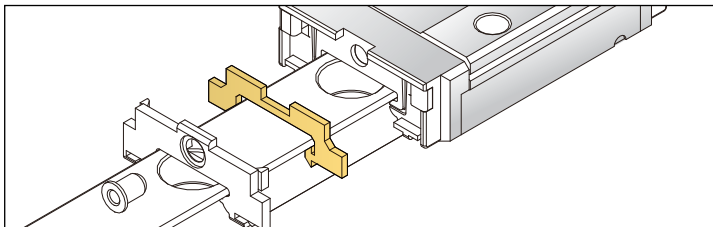

HMR-ee Series Stainless Steel Reinforced Plates Ensure High Robustness

Runner blocks are equipped with two stainless steel plates which reinforce the end-cap from end to end. This sturdier design supports higher running speeds. The plates can also function as scrapers to facilitate smooth travel.

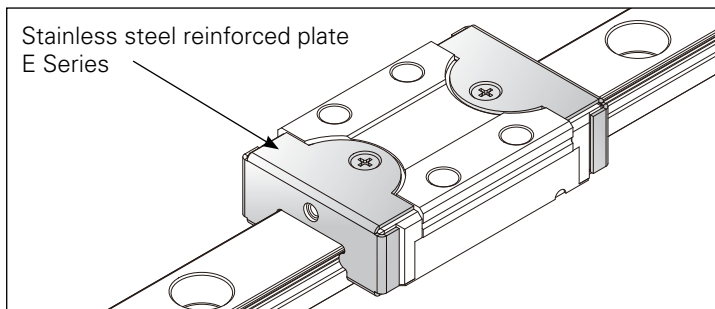

SMA - 14

SIZE 14 - HYBRID LINEAR ACTUATOR (1.8° Step Angle)

MOTOR CHARACTERISTICS

Wiring	Bipolar
Operating Voltage	5 VDC
Current / Phase	0.57 A
Resistance / Phase	8.8 Ω
Inductance / Phase	13 mH
Power Consumption	5.7 W
Temperature Rise	135° F
Weight	5.7 oz (162g)
Insulation Resistance	20 M Ω

SPEED CHARTS

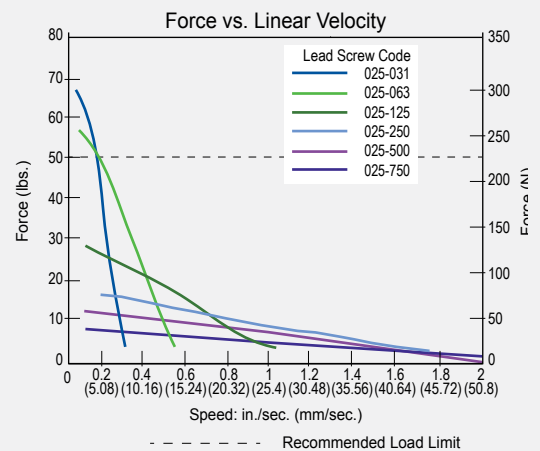
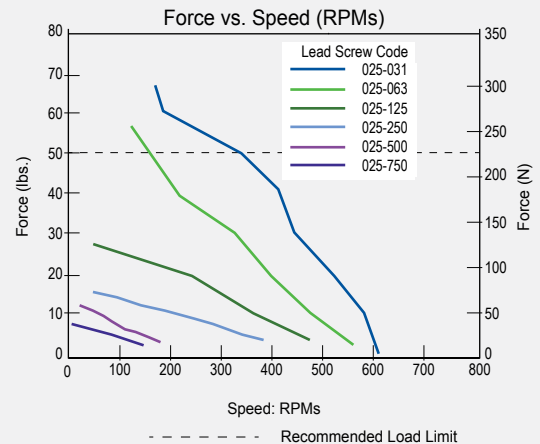

SMA - 17

SIZE 17 - HYBRID LINEAR ACTUATOR (1.8° STEP ANGLE)

MOTOR CHARACTERISTICS

Wiring	Bipolar
Operating Voltage	2.1 VDC
Current / Phase	1.7A
Resistance / Phase	1.2 ohms
Inductance / Phase	1.8 mH
Power Consumption	7 W
Temperature Rise	135° F
Weight	8.5 oz (241g)
Insulation Resistance	20 M Ω

SPEED CHARTS

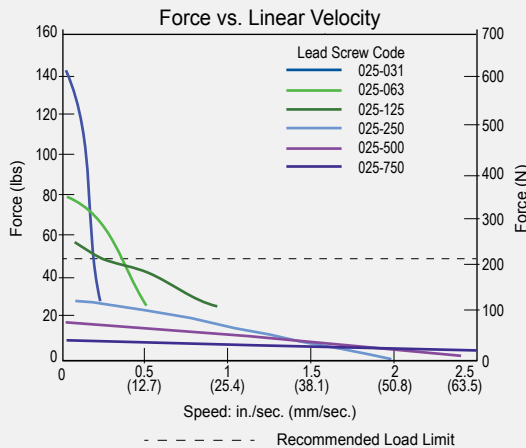
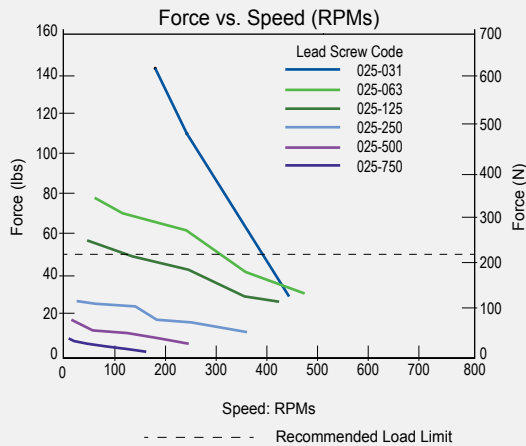

SMA - 23

SIZE 23 - HYBRID LINEAR ACTUATOR (1.8° STEP ANGLE)

MOTOR CHARACTERISTICS

Wiring	Bipolar
Operating Voltage	2.5 VDC
Current / Phase	2.5A
Resistance / Phase	1.0 ohms
Inductance / Phase	2.2 mH
Power Consumption	13 W
Temperature Rise	135° F
Weight	18 oz (511g)
Insulation Resistance	20 M Ω

SPEED CHARTS

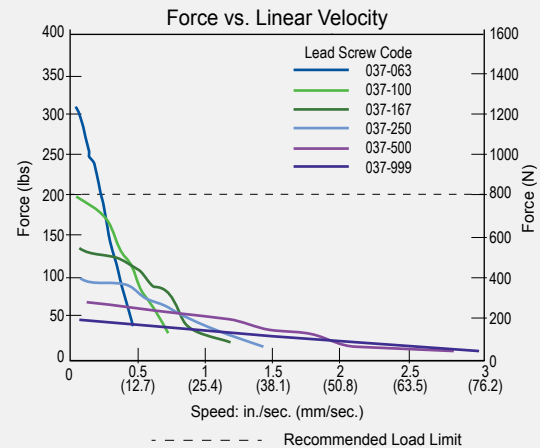
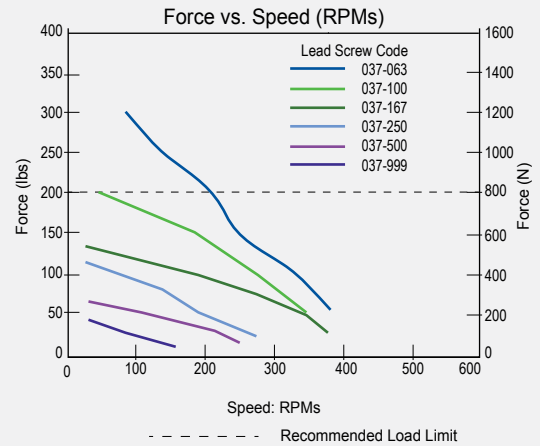

HYBRID STEPPER MOTORS

MOTOR SPECIFICATIONS

NEMA Rating	Motor Power	Current Per Phase	Holding Torque		Detent Torque		Rotor Inertia		Length mm (in)	Weight (g)	Model P.N. #
		A	N•mm	oz•in	N•mm	oz•in	g•cm ²	oz•in ²			
NEMA 14	Single	0.8	180	25.49	10	1.42	13	0.07	34 (1.34)	160	14HY3402
NEMA 14	Double	0.8	220	31.15	15	2.12	22	0.12	42 (1.65)	200	14HY4402
NEMA 14	Triple	0.8	300	42.48	20	2.83	26	0.14	52 (2.05)	230	14HY5402
NEMA 17	Single	1.3	280	39.65	16	2.27	34	0.19	34 (1.34)	220	17HS3401
NEMA 17	Double	1.7	520	73.68	26	3.68	68	0.37	48 (1.89)	350	17HS8401
NEMA 17	Triple	2.3	700	99.12	36	5.09	80	0.44	60 (2.36)	480	17HS9403
NEMA 23	Single	0.6	800	113.29	28	3.96	190	1.04	45 (1.77)	520	23HS4412
NEMA 23	Double	1.0	1500	212.42	50	7.08	380	2.08	64 (2.52)	850	23HS7401
NEMA 23	Triple	3.0	1800	254.90	60	8.49	440	2.41	76 (2.99)	1050	23HS8430

NEMA 14 Hybrid Stepper Motor

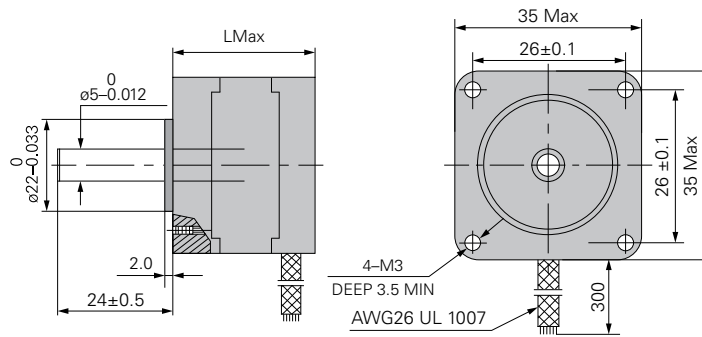

NEMA 17 Hybrid Stepper Motor

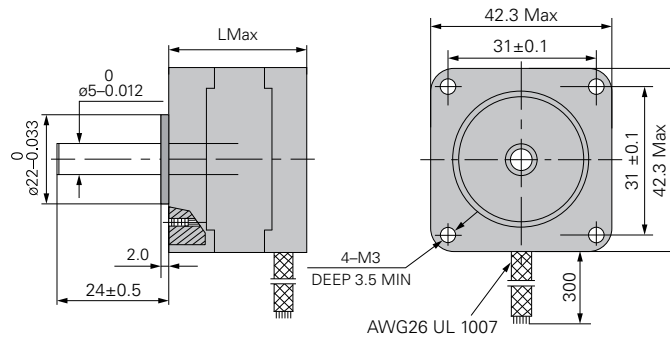

NEMA 23 Hybrid Stepper Motor

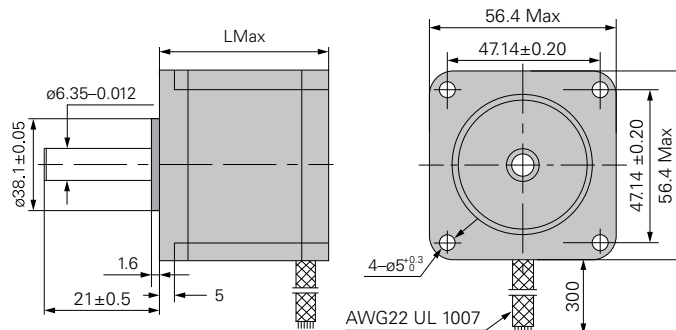

Linear Guidance Options and Specifications

Built with Anodized aluminum and noncorrosive components for years of dependable life - ideal for clean environments. Motors are laser welded to the 300 series stainless screw for additional stiffness and loading. These linear actuators are available with optional encoders, connectors, sensors and custom cables. Standard accessories such as mounting blocks, limit switches and high-payload options are also available.

In addition, Helix offers three rail options including no rail, single rail and double rail with the following characteristics:

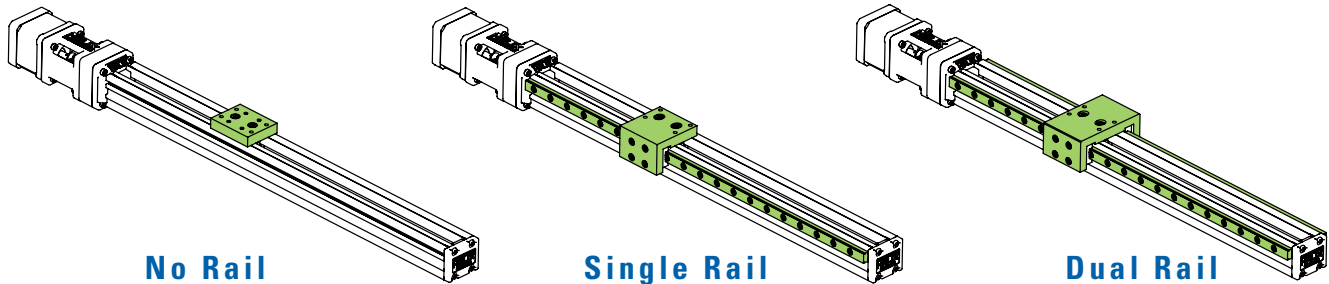

No Rail

Single Rail

Dual Rail

No Rail

Non-motorized. Economical alternative rail. Used for low load, speed. Load can ONLY come from X axis.

Single Rail

NEMA 14, 17 and 23 stepper motor compatible. Higher load and speed. Load can come from X, Y and Z axis.

Double Rail

NEMA 14, 17 and 23 stepper motor compatible. Highest load and speed. Load can come from X, Y and Z axis.

CARRIAGE LOADS

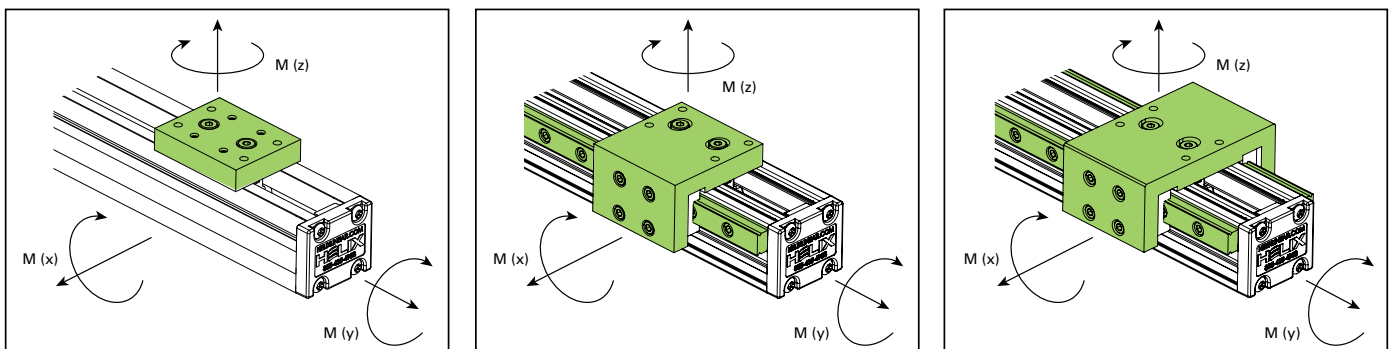

	X	Y	Z	Normal Load
No Rail	Mx = 20 lb/in	Mx = 20 lb/in	Mx = 20 lb/in	Mx = 50 lb/in
Single Rail	Mx = 145 lb/in	Mz = 110 lb/in	Mz = 110 lb/in	Mx = 150 lb/in
Double Rail	Mx = 200 lb/in	My = 300 lb/in	Mz = 200 lb/in	Mx = 300 lb/in

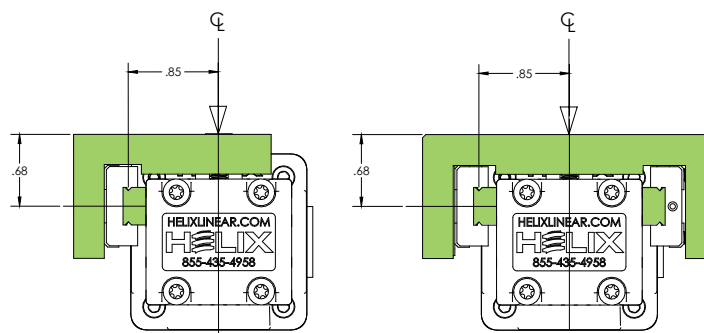

OPTICAL ROTARY ENCODERS

- Designed to provide digital feedback information
- Molded polycarbonate enclosure
- 5-pin or 10-pin finger latching connector (sold separately)
- 32 to 5000 cycles per revolution (CPR)
- 128 to 20000 pulses per revolution (PPR)
- 2 channel quadrature TTL squarewave outputs
- Optional index (3rd channel)
- -25 to +100C operating temperature
- Mounting compatibility with HEDS-5500

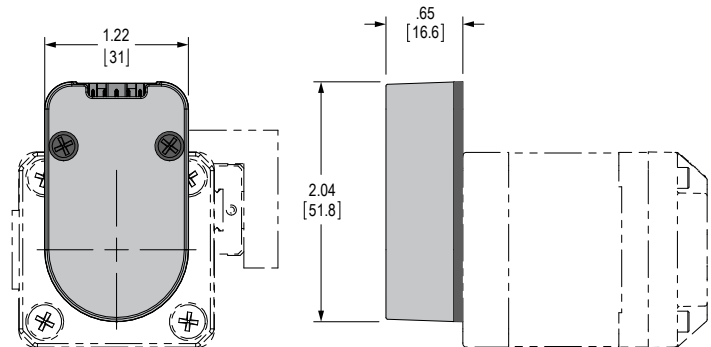

For differential versions: the internal differential line driver (26C31) can source and sink 20mA at TTL levels. The recommended receiver is industry standard 26C32. Maximum noise immunity is achieved when the differential receiver is terminated with a 150 resistor in series with a .0047 F capacitor placed across each differential pair. The capacitor simply conserves power; otherwise power consumption would increase by approximately 20mA per pair, or 60mA for 3 pairs. The mating connectors are available from US Digital with several cable options and lengths.

MAGNETIC SENSORS

- Non-contact sensors determine position of carriage
- Maintains integrity of linear actuator
- Sensors operate without intruding upon the actuator, keeping the system completely intact

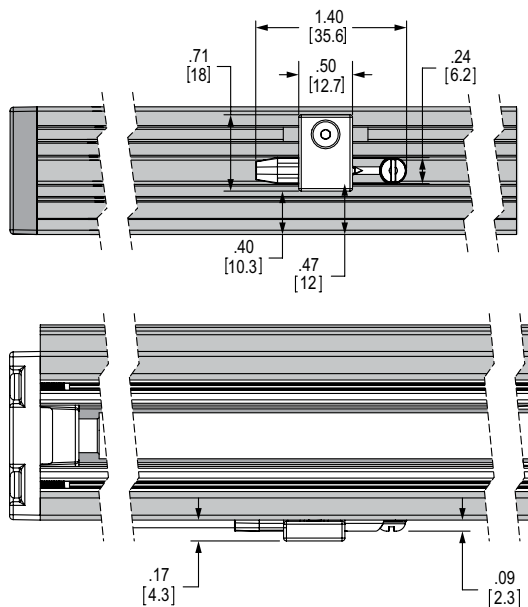

Operating Voltage	5-28 VDC
Voltage Drop	1.0 V
Current Rating	0.2 Amps Max.
Switching Power	4.8 watts Max.
Switching Speed	4µs operate / 4µs release
Short Circuit Protection	No
Reverse Polarity Protection	Yes
Overload Protection	No
Leakage Current	< 0.01 mA
Sensing Technology	GMR
Off Delay Time	150-200 ms
Function Display	PNP switching status yellow / NPN switching status red
Switching Frequency	< 1000 Hz
Magnetic Sensitivity	2.5 millitesla (25 gauss)
Housing Materials	Ultem
Operating Temperature	-4°F to 176°F (-20°C to 80°C)
Protection Rating	NEMA 6 / IP 67
Agency Approvals	CE, RoHS, REACH

LINEAR MOTION APPLICATIONS

High Quality, Precision Linear Motion Solutions

LIFE SCIENCES



- Pipeting automation
- Syringe pumps
- Microscopes
- MRI scanners
- CT scanners
- Radiographic machines
- In-vitro diagnostics
- Genomics
- Blood gas chemistry

PRINTING & BINDING



- "Z" axis actuators
- Multi-axis gantries
- 3D printing
- Automation / Material handling
- Additive manufacturing (AD)
- Large format sign printing
- Digital offset printing process
- Folding and sealing equipment
- Thermal CTP systems

SECURITY - MILITARY



- Automated door locking systems
- Pan-tilt-zoom cameras
- Automated gates
- Tactical automated security cameras
- Missile fin actuation
- Tank sighting systems
- Drones and UAVs
- Torpedo fin actuation
- Guided munitions

SEMICONDUCTOR

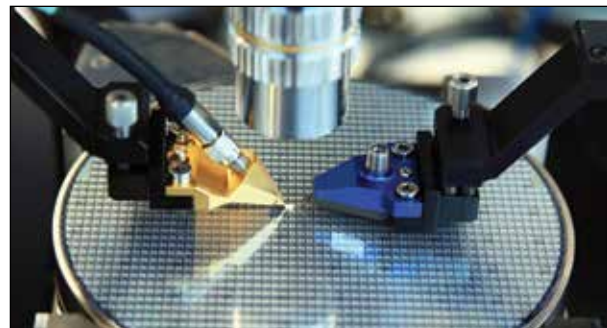

- Burnishing stages
- Stacking systems
- Vision inspection machines
- X, Y, Z gantries
- Wafer elevators / Wafer handling
- Acoustic microscopes
- Ultrasonic imaging
- Tuning coils
- Vacuum chamber doors



helixlinear.com