



## HIGH-SPEED LINEAR GUIDES





**AEROSPACE & DEFENSE**

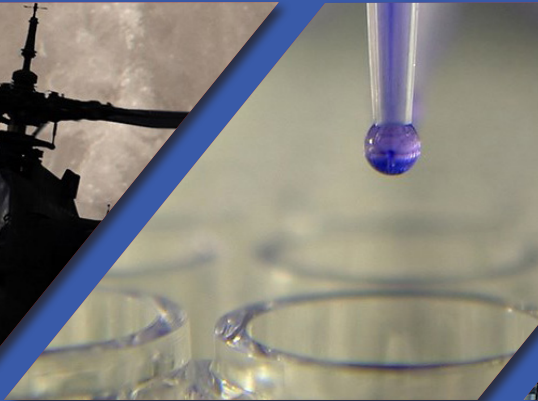

**MEDICAL & LIFE SCIENCE**

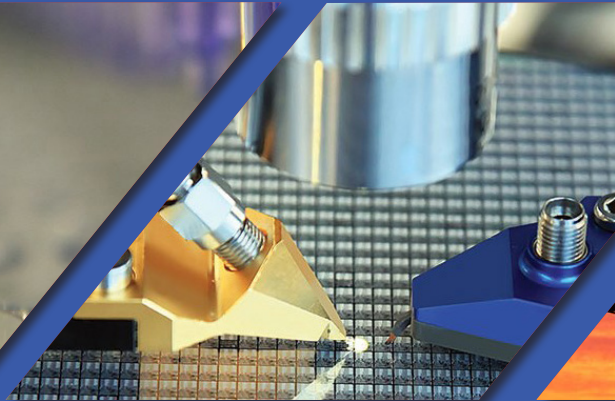

**SEMICONDUCTOR**



**ADDITIVE MANUFACTURING**



**PACKAGING**



**CHEMICAL**

Helix Linear Technologies offers exceptional performance with the highest quality that our customers have come to expect.

We are proud to serve the following industries:



COMMUNICATIONS



FACTORY AUTOMATION



ELECTRONICS



FOOD & BEVERAGE



STEEL & METAL MANUFACTURING



AUTOMOTIVE

**HELIX LINEAR IS A GLOBAL LEADER IN LINEAR MOTION TECHNOLOGIES.**

For nearly 50 years the company has helped its customers engineer their own success in a wide range of markets. Helix Linear leads with its innovative design, engineering, and manufacturing of precision linear motion and power transmission systems. Helix Linear focuses on engineering and manufacturing lead screws and linear actuators.



## Strategy

Helix Linear Technologies produces cost-effective, precision linear motion systems and components using leading-edge technology, equipment and production methods.



## Collaboration

For nearly 50 years Helix Linear Technologies has been innovating together with our customers to design, engineer and manufacture our wide range of products for a variety of markets.



## Solutions

Full range of product solutions to fit all our customers performance needs; whether the application requires an off-the-shelf linear motion component or a custom engineered solution, Helix Linear Technologies offers exceptional performance with the highest quality.



**Helix Linear Technologies**, a subsidiary of Nook Industries, is the most high-tech lead screw manufacturing facility in the world. With the release of our new precision lead screws, Helix produces the broadest product line of any lead screw manufacturer globally. We offer precision rolled, milled, or ground screws in diameters from 1/8"= to 6", or 3mm to 150mm, and leads from 0.024" to 3", or 3mm to 75mm. Helix offers a complete line of nuts in standard and anti-backlash designs with centralizing threads to match our precision lead screws. Our lead screw assemblies have the lowest backlash on the market. Helix is committed to customer success and innovation by providing high-quality, high-value products and service that are delivered on time at a competitive price. Pairing traditional and proven design with the latest technology, Helix Linear Technologies manufactures products that customers value. The expansion of our product lines and the development of engineered systems have propelled Helix to the forefront of the industry.

## LGA LINEAR GUIDE

### Construction

LGA linear guide systems are mainly made of lightweight material of aluminum alloy. Four rollers inside the carriage run on railway's hardened shafts. Stable rolling movement are particularly suitable for use in material handling system and automatic production lines. The following picture shows its construction.

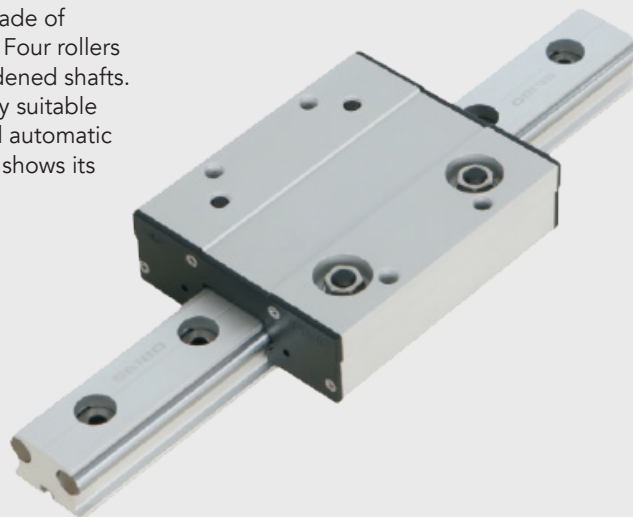

### Railway

Anodized aluminum alloy body with two Chrome-plated steel shafts.

### Carriage

- Anodized aluminum alloy plate
- 4 pieces double row balls bearings(Rollers)
- 2 pieces concentric bolts and 2 pieces eccentric bolts
- 2 pieces plastic lubrication cover with oil soaked felt wipers

### Feature

1. High speed, Low friction and Low noise
2. Preload is adjustable
3. Sealed and Lubricated

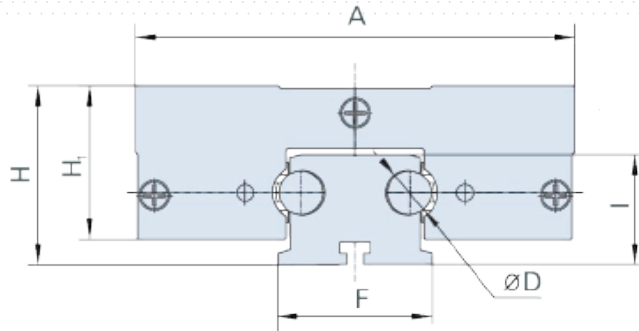

Type	Assembly Dimensions		Carriage Dimensions				
	H	F	A	B	C	E	M <sub>1</sub>
HSB-LGA20	30	20	63	92	53	40	26
HSB-LGA25	32.5	28	80	105	60	40	28
HSB-LGA30	38.5	34.2	100	120	85	50	33

M x depth	Railway Dimensions						
	D	G x depth	G <sub>1</sub>	I	S	P	L <sub>max</sub> *
M6x8	6	9x5.5	5.5	19.5	30	60	1020
M6x8	8	12.5x5.5	5.5	20	25	50	3000
M8x10	10	14.5x6.5	6.5	24	25	50	4000

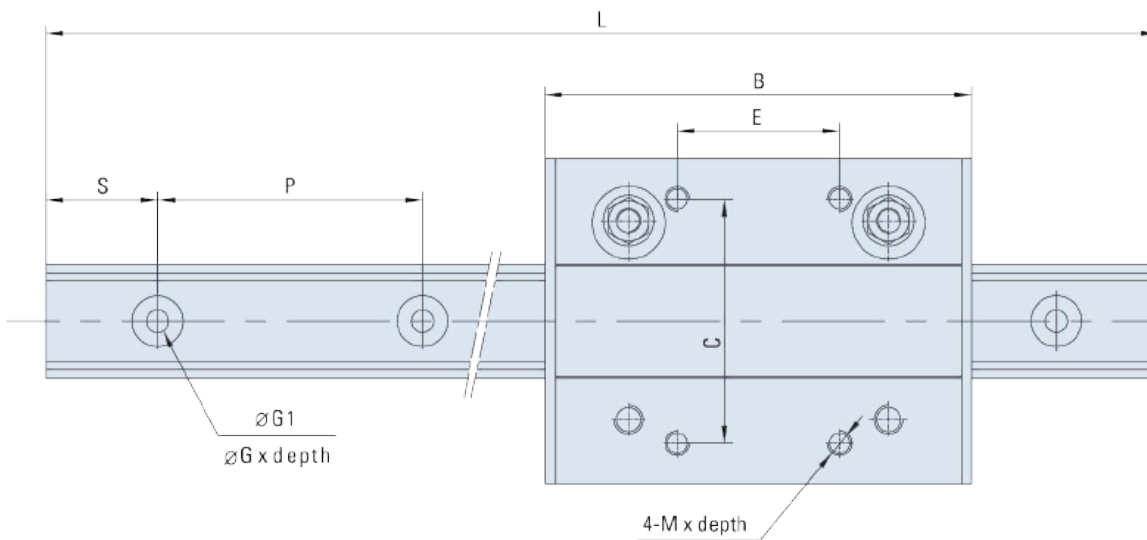

## Setting Clearance-Free

None clearance is necessary for system's rigidity and stability. LGA series use 2 concentric bolts on one side in the direction of railway and 2 eccentric bolts on the other side. These two eccentric bolts are used for setting clearance-free.

1. Tighten concentric bolts.
2. Tighten the eccentric bolts to near the critical point, but not
3. reach the critical point. (This is to rotate the eccentric bolts).
4. Rotate the eccentric bolts with straight screwdriver at the end
5. of the stud to adjust the clearance. Adjust the clearance to zero.
6. Slide the carriage by hand and adjust to the extent where
7. there causes a slight slipping resistance.
8. Keep eccentric bolt's position and tighten the nut.

## Setting Pre-Load

It is same as Setting clearance-free. First adjust clearance to zero, continue rotating eccentric bolts will get pre-load. Appropriate pre-load should be decided according to the application. Over pre-load will decrease system's life. Please be careful.

## Lubrication

Plastic lubrication cover contains oil soaked felt wipers which can be re-lubricated via lubrication holes.

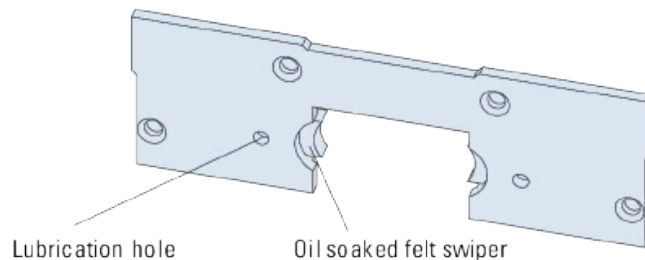

## Working Parameter

Max speed: 10m/s  
 Max acceleration: 50m/s  
 Working temperature: -20°C ~ +80°C

## Accuracy

Tolerance H:  $\pm 0.20\text{mm}$   
 Note: Higher accuracies are available upon request.

*The specifications and data in this publication are believed to be accurate and reliable. However, it is the responsibility of the product user to determine the suitability of Helix products for a specific application. While defective products will be replaced without charge if promptly returned, no liability is assumed beyond such replacement.*

## Load / Life Calculation

Due to the hardness of the railway's shaft and fatigue analysis of railway and roller, the railway's life does not determine the system life. It is determined by roller's life. System's life varies by actual combination of load, working status and environment conditions etc. So loading factor should be calculated firstly. Then system's life could be calculated via using below formula.

### LF - Loading Factor (LF should be less than 1.0 for any combination of load)

$$LF = \frac{F_y}{F_{y\max}} + \frac{F_z}{F_{z\max}} + \frac{M_x}{M_{x\max}} + \frac{M_y}{M_{y\max}} + \frac{M_z}{M_{z\max}}$$

- F<sub>y</sub> – Actual load in Y direction (N)
- F<sub>z</sub> – Actual load in Z direction (N)
- M<sub>x</sub>- Actual moment load in X direction (N.m)
- M<sub>y</sub>- Actual moment load in Y direction (N.m)
- M<sub>z</sub>- Actual moment load in Z direction (N.m)

(Below Parameters can be taken from the table of Load Capacity)

- F<sub>y</sub> max - Max load capacity in Y direction. (N)
- F<sub>z</sub> max - Max load capacity in Z direction. (N)
- M<sub>x</sub> max - Max moment capacity in X direction. (N.m)
- M<sub>y</sub> max - Max moment capacity in Y direction. (N.m)
- M<sub>z</sub> max - Max moment capacity in Z direction. (N.m)

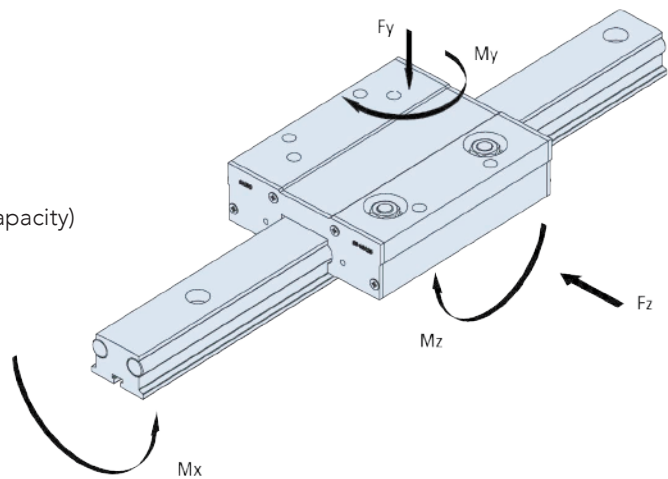

## Load Capacity

Railway Type	Max Load Capacity (N)		Max Moment Capacity (N.m)		
	F <sub>y</sub> max	F <sub>z</sub> max	M <sub>x</sub> max	M <sub>y</sub> max	M <sub>z</sub> max
HSB-LGA20	330	600	1.8	7	5.8
HSB-LGA25	520	1200	7.6	26	15
HSB-LGA30	1200	4000	26	78	45

## Life Calculation

SAIBO designed LGA series load capacity according to basic life of 100km for each type. System's life in km could be calculated via below formula.

f - Reduction coefficient of the application and environment.

$$\text{Life(km)} = \frac{100}{(0.03+0.97LF*f)^3}$$

None vibration or shock, Low speed (<1m/s), Low frequency shift direction, clean environment. 1 - 1.5

Light vibration or shock, medium speed (1-2.5m/s), medium frequency shift direction, some dirtiness 1.5 - 2

Heavy vibration or shock, high speed (>2.5m/s), high frequency shift direction, heavy dirty 2 - 3.5



## Calculation Example

Here select SB-LGA25 as calculation example. This system is loaded as below picture.  
Working condition is clean and there is no vibration or shock.

## The load factor LF is calculated use formula

Tolerance H: ±0.20mm

Note: Higher accuracies are available upon request.

$$LF = \frac{F_y}{F_{y\max}} + \frac{F_z}{F_{z\max}} + \frac{M_x}{M_{x\max}} + \frac{M_y}{M_{y\max}} + \frac{M_z}{M_{z\max}}$$

$$F_y = 5 \text{ kg} \times 9.8 \text{ (gravity)} = 49 \text{ N}$$

$$F_z = 10 \text{ N}$$

$$M_x = 49 \times 0.02 = 0.98 \text{ N}\cdot\text{m}$$

$$M_y = 0$$

$$M_z = 0$$

Take parameters  $F_y \max$ ,  $F_z \max$ ,  $M_x \max$ ,  $M_y \max$ ,  $M_z \max$  from table and then fill in the formula

$$LF = \frac{49}{520} + \frac{10}{1200} + \frac{0.98}{7.60} + \frac{0}{M_{y\max}} + \frac{0}{M_{z\max}} = 0.2314$$

According to the description of working condition, take  $f=1.1$

$$\begin{aligned} \text{Life(km)} &= \frac{100}{(0.03+0.97LF*f)^3} \\ &= \frac{100}{(0.03+0.97*0.2314*1.1)^3} \\ &= 4716\text{km} \end{aligned}$$

## LGB LINEAR GUIDE

### Construction

LGB linear guide systems are designed for compact space application. The carriages are in narrow structures. Railway, narrow carriage and lubrication cover are its basic construction.

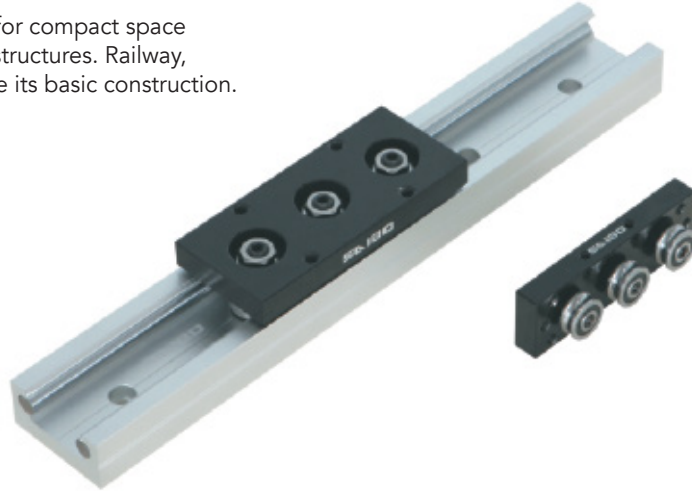

### Railway

Anodized aluminum alloy body with two Chrome-plated steel shafts.

### Carriage

Anodized aluminum alloy plate

3 pieces double row balls bearings (Rollers)

Eccentric bolt used for adjust the clearance/preload

Optional lubrication covers with oil soaked felt wipers

### Feature

1. High speed, Low friction and Low noise
2. Preload is adjustable
3. Narrow body for compact application
4. Optional Lubrication covers

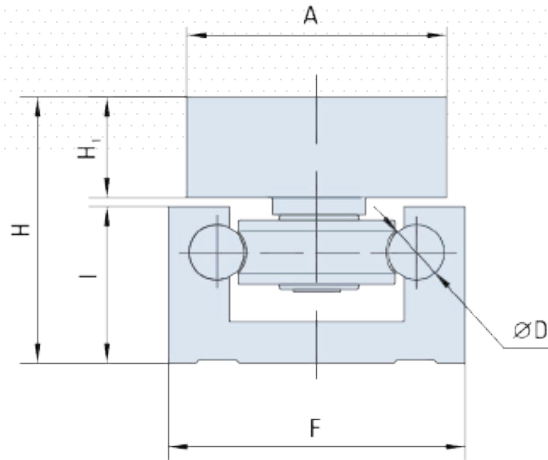

Type	Assembly Dimensions		Carriage Dimensions				
	H	F	A	B*	C	E	E <sub>1</sub>
HSB-LGB15	28.8	32	28	88	20	70	5
HSB-LGB20	35.5	47	47	108	38	50	-
HSB-LGB25	43	65	64	150	47	130	65

\* This size does not include plastic cover's thickness.  
 All size plastic cover's thickness is 2.5mm. So covered carriages' length must add 5.0mm to size B.

H <sub>1</sub>	M	Railway Dimensions						
		D	G x depth	G <sub>1</sub>	I	S	P	L <sub>max</sub>
10.9	4xM5	6	7.5x2.5	4.5	17	30	60	3000
11.5	4xM6	8	9.5x5	5.5	21.75	30	60	3000
14.7	6xM8	10	11x4	6.5	26.5	30	60	3000

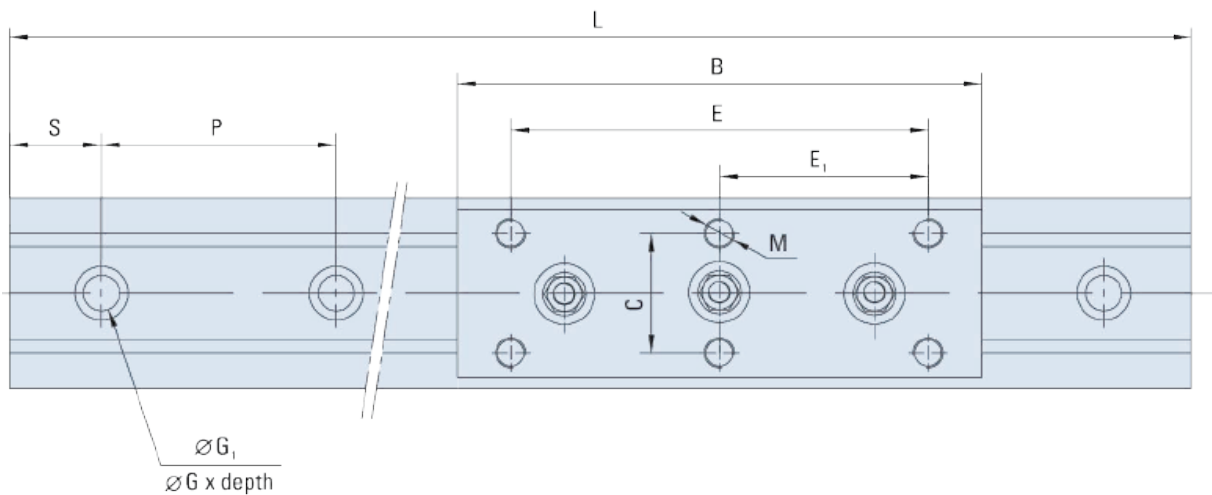

The specifications and data in this publication are believed to be accurate and reliable. However, it is the responsibility of the product user to determine the suitability of Helix products for a specific application. While defective products will be replaced without charge if promptly returned, no liability is assumed beyond such replacement.

## Setting Clearance-Free

None clearance is necessary for system's rigidity and stability. LGB series carriage has two concentric bolts on both sides and one eccentric bolt in the center along the railway. This eccentric bolt is used for setting clearance-free.

1. Tighten concentric bolts.
2. Tighten the eccentric bolt to near the critical point, but not reach the critical point. (This is for rotate the eccentric bolts).
3. Rotate the eccentric bolts with internal hexagonal wrench in the end of the eccentric bolt to adjust the clearance. Adjust the clearance to zero.
4. Slide the carriage by hand and adjust to the extent where there causes a slight slipping resistance.
5. Keep eccentric bolt's position and tighten the nut.

## Setting Pre-Load

It is same as Setting clearance-free. First adjust clearance to zero, continue rotating eccentric bolt will get pre-load. Appropriate pre-load should be decided according to application. Over pre-load will decrease system's life. Please be careful.

## Lubrication

Plastic lubrication cover contains oil soaked felt wipers which can be relubricated via lubrication hole. This lubrication cover is optional, not included in standard carriage.

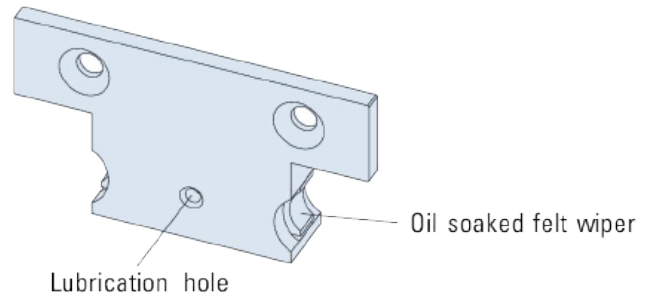

## Working Parameter

Max speed: 10m/s  
 2 Max acceleration: 50m/s  
 Working temperature: -20°C ~ +80°C

## Accuracy

Tolerance H:  $\pm 0.20\text{mm}$   
 Note: Higher accuracies are available upon request.

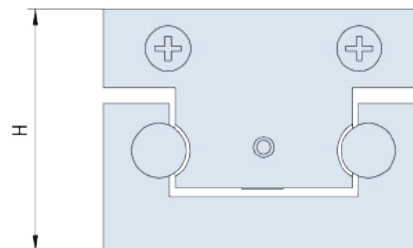

## Load / Life Calculation

Due to the hardness of the railway's shaft and fatigue analysis of railway and roller, the railway's life does not determine the system life. It is determined by roller's life. System's life varies by actual combination of load, working status and environment conditions etc. So loading factor should be calculated firstly. Then system's life could be calculated via using below formula.

### LF - Loading Factor (LF should be less than 1.0 for any combination of load)

$$LF = \frac{F_y}{F_{y\max}} + \frac{F_z}{F_{z\max}} + \frac{M_x}{M_{x\max}} + \frac{M_y}{M_{y\max}} + \frac{M_z}{M_{z\max}}$$

- F<sub>y</sub> - Actual load in Y direction. (N)
- F<sub>z</sub> - Actual load in Z direction. (N)
- M<sub>x</sub> - Actual moment in X direction. (N.m)
- M<sub>y</sub> - Actual moment in Y direction. (N.m)
- M<sub>z</sub> - Actual moment in Z direction. (N.m)

Below parameters can be taken from the table of Load capacity.

- F<sub>y</sub> max - Max load capacity in Y direction. (N)
- F<sub>z</sub> max - Max load capacity in Z direction. (N)
- M<sub>x</sub> max - Max moment capacity in X direction. (N.m)
- M<sub>y</sub> max - Max moment capacity in Y direction. (N.m)
- M<sub>z</sub> max - Max moment capacity in Z direction. (N.m)

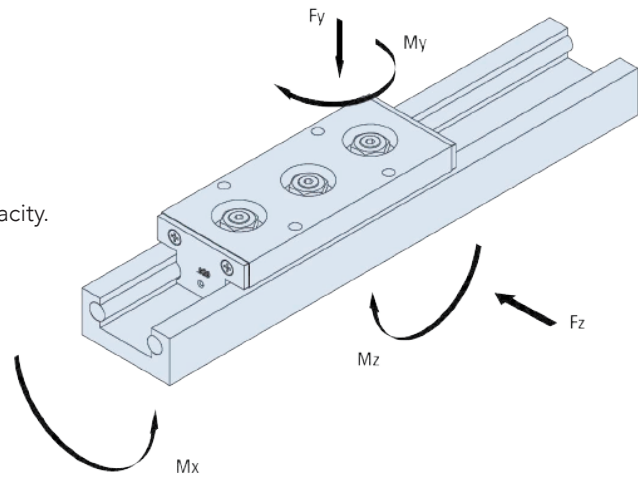

## Load Capacity

Railway Type	Max Load Capacity (N)		Max Moment Capacity (N.m)		
	F <sub>y</sub> max	F <sub>z</sub> max	M <sub>x</sub> max	M <sub>y</sub> max	M <sub>z</sub> max
HSB-LGB15	330	1000	1.8	12	5.5
HSB-LGB20	520	1200	6.6	45	15
HSB-LGB25	1200	4000	19	120	50

## Life Calculation

SAIBO designed LGB series load capacity according to basic life of 100km for each type. So after customers designed system's actual load, system's life could be calculated via below formula.

f - Reduction coefficient of the application and environment.

$$\text{Life(km)} = \frac{100}{(0.03+0.97LF*f^3)}$$

None vibration or shock, Low speed (<1m/s), Low frequency shift direction, clean environment. 1 - 1.5

Light vibration or shock, medium speed (1-2.5m/s), medium frequency shift direction, some dirtiness. 1.5 - 2

Heavy vibration or shock, high speed (>2.5m/s), high frequency shift direction, heavy dirty. 2 - 3.5

The specifications and data in this publication are believed to be accurate and reliable. However, it is the responsibility of the product user to determine the suitability of Helix products for a specific application. While defective products will be replaced without charge if promptly returned, no liability is assumed beyond such replacement.

## Calculation Example

Here select SB-LGB20 as calculation example. This system loaded as below picture.  
Working condition is clean and there is no vibration or shock.

## The load factor LF is calculated use formula

$$LF = \frac{F_y}{F_{y\max}} + \frac{F_z}{F_{z\max}} + \frac{M_x}{M_{x\max}} + \frac{M_y}{M_{y\max}} + \frac{M_z}{M_{z\max}}$$

$$F_y = 6 \text{ kg} \times 9.8 \text{ (gravity)} = 58.8 \text{ N}$$

$$F_z = 10 \text{ N}$$

$$M_x = 10 \times 0.04 = 0.40 \text{ N}\cdot\text{m}$$

$$M_y = 0$$

$$M_z = 0$$

Take parameters  $F_y \max$ ,  $F_z \max$ ,  $M_x \max$ ,  $M_y \max$ ,  $M_z \max$  from table and then fill in the formula

$$LF = \frac{58.8}{520} + \frac{10}{1200} + \frac{0.40}{6.60} + \frac{0}{M_{y\max}} + \frac{0}{M_{z\max}} = 0.182$$

According to the description of working condition of light shock,  
take  $f=1.1$

$$\begin{aligned} \text{Life(km)} &= \frac{100}{(0.03+0.97LF*f)^3} \\ &= \frac{100}{(0.03+0.97*0.182*1.1)^3} \\ &= 8849\text{km} \end{aligned}$$

## LGC LINEAR GUIDE

### Construction

LGC railway is wide structure. This linear guide can be used to replace the system built with two railways and has big load capacity and moment capacity. Especially the moment load is much bigger as two shafts' span is big.

Although railway's width is big, light-weight aluminum alloy still keep railway's weight light. In the body of the railway, there is a big U-shape groove. This groove is used for installing driven parts such as rack and gear, timing belt.

### Features

- 1.High speed, Low friction and Low noise
- 2.Big load capacity and moment capacity
- 3.Pre-load is adjustable
- 4.Accurate and stable

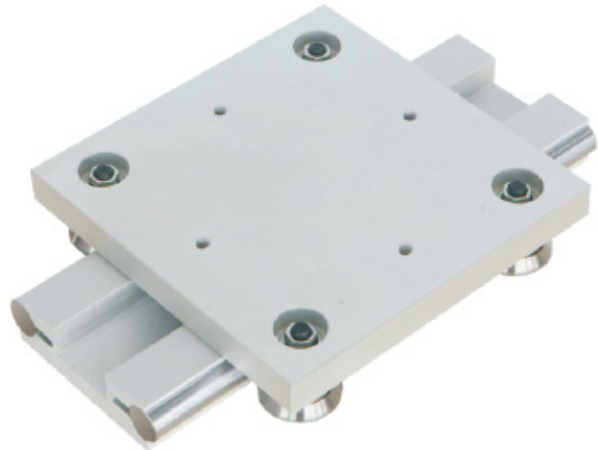

### Advantage compare with two railways

Compare to the structure by using two railways, LGC linear guide's advantages are:

1. Easy to install the railway.

When install two railways, two railways' parallel must be controlled strictly. And it is a trouble. LGC linear guide does not need this job.

2. Dia20 shaft make system's rigidity and strength stronger.

This can make carriage's load capacity much bigger. And also the system's stability will improve a lot.

3. Increase system's life.

According to life calculation formula, Life Factor (LF) is the main determinant of the life. At same load capacity, LGC linear guide's LF will be much smaller than by using two railways. This will increase system's life.

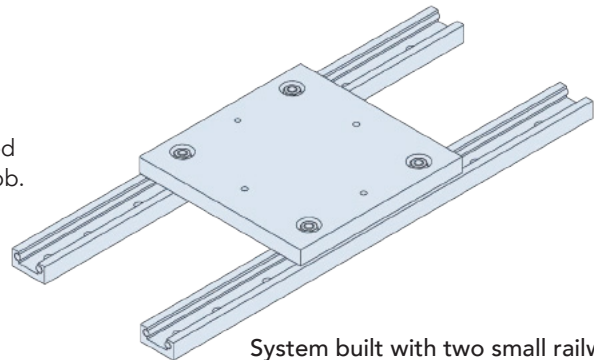

System built with two small railways.

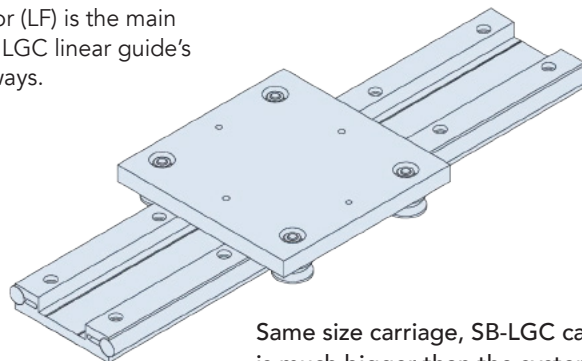

Same size carriage, SB-LGC carriage's load capacity is much bigger than the system built with two railways.

*The specifications and data in this publication are believed to be accurate and reliable. However, it is the responsibility of the product user to determine the suitability of Helix products for a specific application. While defective products will be replaced without charge if promptly returned, no liability is assumed beyond such replacement.*

## Setting Clearance-Free

---

None clearance is necessary for system's rigidity and stability. LGC series use 2 concentric bolts one side in the direction of railway and 2 eccentric bolts on the other side. These two eccentric bolts are used for setting clearance-free.

1. Tighten concentric bolts.
2. Tighten the eccentric bolts to near the critical point, but not reach the critical point. (This is to rotate the eccentric bolts).
3. Rotate the eccentric bolts with wrench at the end of the stud to adjust the clearance. Adjust the clearance to zero.
4. Slide the carriage by hand and adjust to the extent where there causes a slight slipping resistance.
5. Keep eccentric bolt's position and tighten the nut.

## Setting Pre-Load

---

It is same as Setting clearance-free. First adjust clearance to zero, continue rotating eccentric bolts will get pre-load. Appropriate preload should be decided according to application. Over pre-load will decrease system's life. Please be careful.

## Working Parameter

---

Ma x speed: 10m/s  
2 Max acceleration: 50m/s  
Working temperature: -20°C ~ +80°C

## Accuracy

---

Tolerance H:  $\pm 0.20\text{mm}$   
Note: Higher accuracies are available upon request.





Dimensions

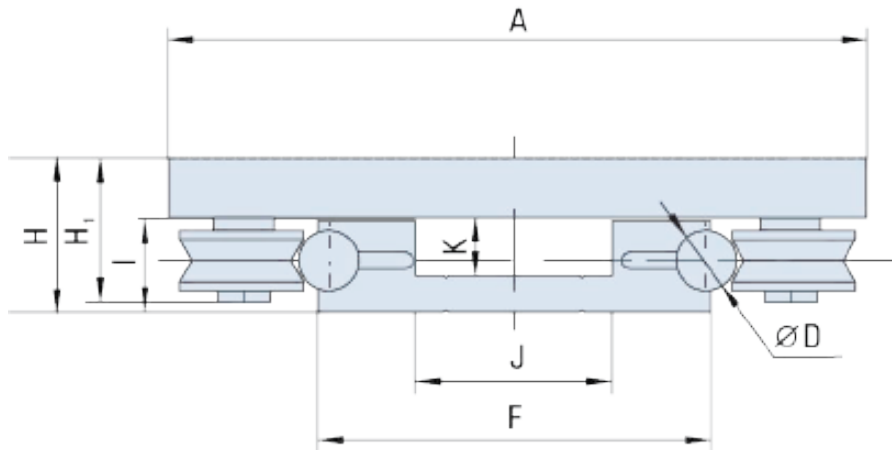

Type	Assembly Dimensions		Carriage Dimensions					
	H	F	A	B	C	E	H <sub>1</sub>	M
HSB-LGC100	51	99	200	200	140	140	48	4-M8
HSB-LGC130	51	130	230	230	180	160	48	4-M8

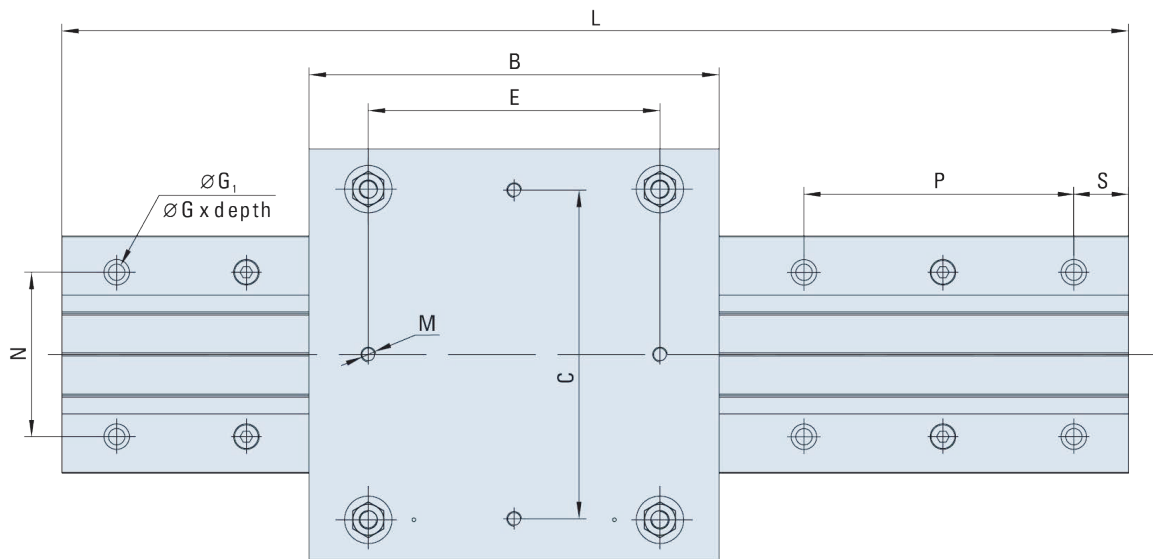

Railway Dimensions									
D	G x depth	G <sub>1</sub>	I	J	K	N	S	P	L <sub>max</sub> *
20	14x5.5	9	30	40	18	62	30	300	6000
20	14x5.5	9	30	65	18	90	30	300	6000

The specifications and data in this publication are believed to be accurate and reliable. However, it is the responsibility of the product user to determine the suitability of Helix products for a specific application. While defective products will be replaced without charge if promptly returned, no liability is assumed beyond such replacement.

## Load / Life Calculation

Due to the hardness of the railway's shaft and fatigue analysis of railway and roller, the railway's life does not determine the system life. It is determined by roller's life. System's life varies by actual combination of load, working status and environment conditions etc. So loading factor should be calculated firstly. Then system's life could be calculated via using below formula.

**LF - Loading Factor** (LF should be less than 1.0 for any combination of load)

$$LF = \frac{F_y}{F_{y\max}} + \frac{F_z}{F_{z\max}} + \frac{M_x}{M_{x\max}} + \frac{M_y}{M_{y\max}} + \frac{M_z}{M_{z\max}}$$

$F_y$  - Actual load in Y direction. (N)

$F_z$  - Actual load in Z direction. (N)

$M_x$  - Actual moment in X direction. (N.m)

$M_y$  - Actual moment in Y direction. (N.m)

$M_z$  - Actual moment in Z direction. (N.m)

Below parameters can be taken from the table of Load capacity.

$F_y \max$  - Max load capacity in Y direction. (N)

$F_z \max$  - Max load capacity in Z direction. (N)

$M_x \max$  - Max moment capacity in X direction. (N.m)

$M_y \max$  - Max moment capacity in Y direction. (N.m)

$M_z \max$  - Max moment capacity in Z direction. (N.m)

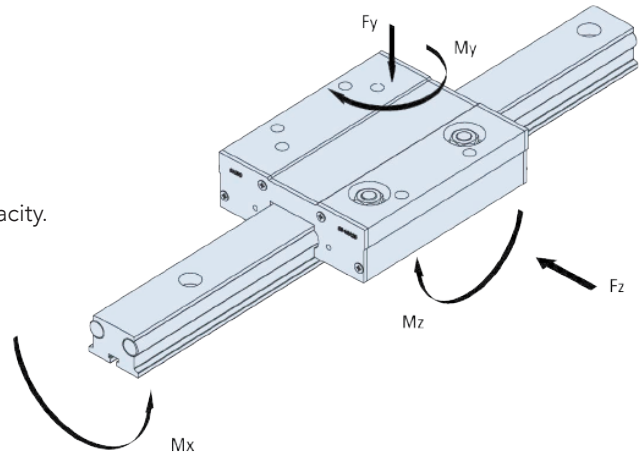

## Load Capacity

Railway Type	Max Load Capacity (N)		Max Moment Capacity (N.m)		
	$F_{y\max}$	$F_{z\max}$	$M_{x\max}$	$M_{y\max}$	$M_{z\max}$
SB-LGC100	6000	6000	190	210	210
SB-LGC130	6000	6000	240	240	240

## Life Calculation

SAIBO designed LGC linear guide load capacity according to basic life of 100km. System's life in km could be calculated using below formula.

$f$  - Reduction coefficient of the application and environment.

$$\text{Life(km)} = \frac{100}{(0.03 + 0.97LF * f^3)}$$

None vibration or shock, Low speed (<1m/s),  
Low frequency shift direction, clean environment. 1 - 1.5

Light vibration or shock, medium speed (1-2.5m/s),  
medium frequency shift direction, some dirtiness 1.5 - 2

Heavy vibration or shock, high speed (>2.5m/s),  
high frequency shift direction, heavy dirty 2 - 3.5

## Calculation Example

Here we select a load example to calculate the life. Sample's load is as below picture.  
Working condition is clean and there is no vibration or shock.

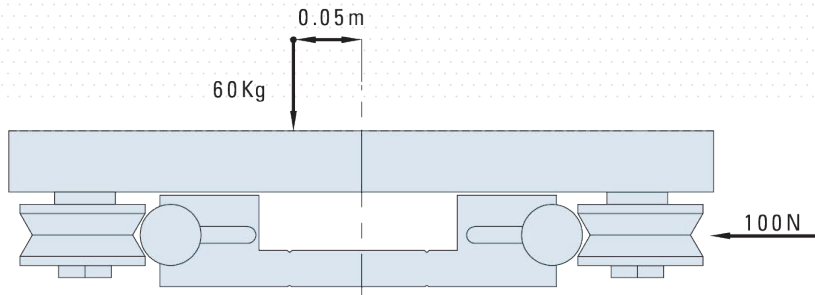

## The load factor LF is calculated use formula

$$LF = \frac{F_y}{F_{y\max}} + \frac{F_z}{F_{z\max}} + \frac{M_x}{M_{x\max}} + \frac{M_y}{M_{y\max}} + \frac{M_z}{M_{z\max}}$$

$$F_y = 60\text{kg} \times 9.8 \text{ (gravity)} = 588 \text{ N}$$

$$F_z = 100 \text{ N}$$

$$M_x = 588 \times 0.05 = 29.4 \text{ N}\cdot\text{m}$$

$$M_y = 0$$

$$M_z = 0$$

Take parameters  $F_y \max$ ,  $F_r \max$ ,  $M_x \max$ ,  $M_y \max$ ,  $M_z \max$  from table and then fill in the formula

$$LF = \frac{588}{6000} + \frac{10}{6000} + \frac{29.4}{240} + \frac{0}{M_{y\max}} + \frac{0}{M_{z\max}} = 0.2372$$

According to the description of working condition, take  $f=1.1$

$$\begin{aligned} \text{Life(km)} &= \frac{100}{(0.03+0.97LF*f)^3} \\ &= \frac{100}{(0.03+0.97*0.2372*1.1)^3} \\ &= 4405\text{km} \end{aligned}$$

All rights reserved. Due to constant development of the products,  
we reserve the right of modifications without notifications.



**HELIX LINEAR TECHNOLOGIES**  
23200 Commerce Park Road  
Beachwood, OH 44122  
1-855-HELIXLT or 216-485-2232

[www.helixlinear.com](http://www.helixlinear.com)  
[sales@helixlinear.com](mailto:sales@helixlinear.com)

