

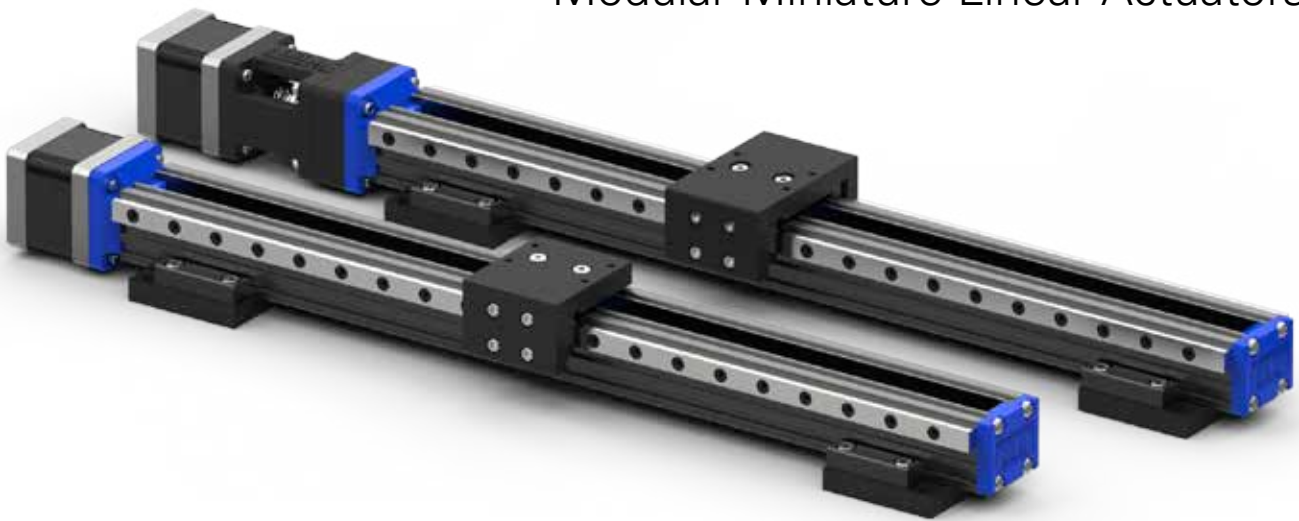

MICRO PRECISION LINEAR ACTUATORS

Modular Miniature Linear Actuators



MOTOR SPECIFICATIONS

NEMA Rating	Motor Power	Current Per Phase	Holding Torque		Detent Torque		Rotor Inertia		Length mm (in)	Weight (g)	Model P.N. #
		A	N•mm	oz•in	N•mm	oz•in	g•cm ²	oz•in ²			
NEMA 14	Single	0.8	180	25.49	10	1.42	13	0.07	34 (1.34)	160	14HY3402
NEMA 14	Double	0.8	220	31.15	15	2.12	22	0.12	42 (1.65)	200	14HY4402
NEMA 14	Triple	0.8	300	42.48	20	2.83	26	0.14	52 (2.05)	230	14HY5402
NEMA 17	Single	1.3	280	39.65	16	2.27	34	0.19	34 (1.34)	220	17HS3401
NEMA 17	Double	1.7	520	73.68	26	3.68	68	0.37	48 (1.89)	350	17HS8401
NEMA 17	Triple	2.3	700	99.12	36	5.09	80	0.44	60 (2.36)	480	17HS9403
NEMA 23	Single	0.6	800	113.29	28	3.96	190	1.04	45 (1.77)	520	23HS4412
NEMA 23	Double	1.0	1500	212.42	50	7.08	380	2.08	64 (2.52)	850	23HS7401
NEMA 23	Triple	3.0	1800	254.90	60	8.49	440	2.41	76 (2.99)	1050	23HS8430

See following pages for detailed specifications



MICRO PRECISION LINEAR ACTUATORS

Modular Miniature Linear Actuators

SMA - 14

SIZE 14 - HYBRID LINEAR ACTUATOR
(1.8° Step Angle)

MOTOR CHARACTERISTICS

Wiring	Bipolar
Operating Voltage	5 VDC
Current / Phase	0.57 A
Resistance / Phase	8.8 Ω
Inductance / Phase	13 mH
Power Consumption	5.7 W
Temperature Rise	135° F
Weight	5.7 oz (162g)
Insulation Resistance	20 M Ω

NEMA 14 Hybrid Stepper Motor

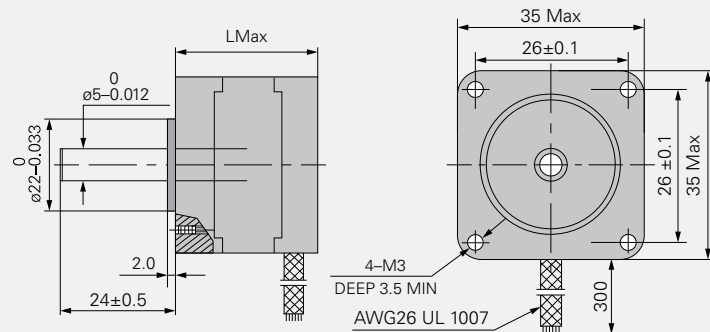
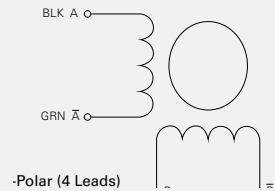

SPEED CHARTS

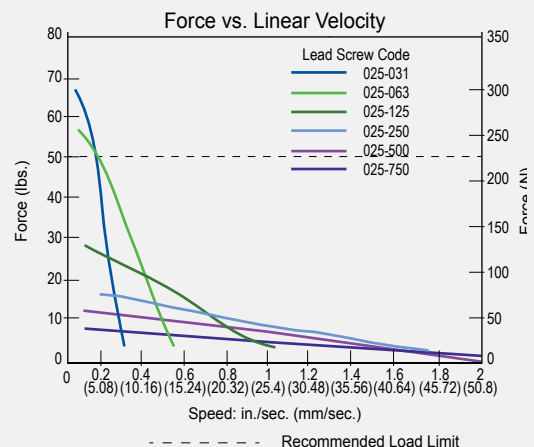
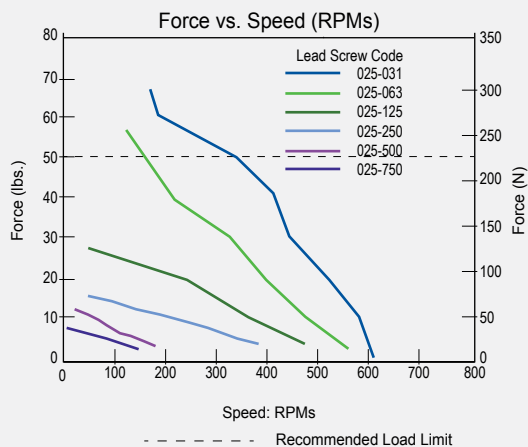



MICRO PRECISION LINEAR ACTUATORS

Modular Miniature Linear Actuators

SMA - 17

**SIZE 17 - HYBRID LINEAR ACTUATOR
(1.8° STEP ANGLE)**

MOTOR CHARACTERISTICS

Wiring	Bipolar
Operating Voltage	2.1 VDC
Current / Phase	1.7A
Resistance / Phase	1.2 ohms
Inductance / Phase	1.8 mH
Power Consumption	7 W
Temperature Rise	135° F
Weight	8.5 oz (241g)
Insulation Resistance	20 M Ω

NEMA 17 Hybrid Stepper Motor

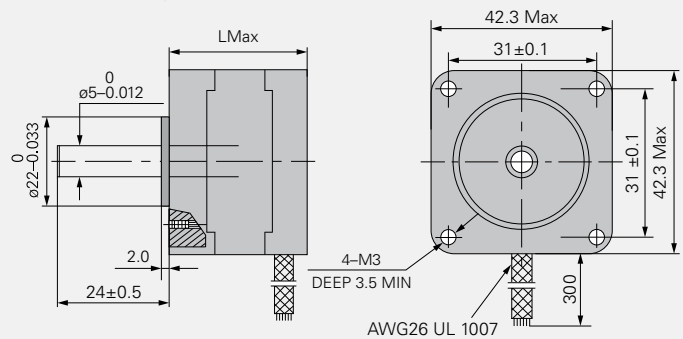
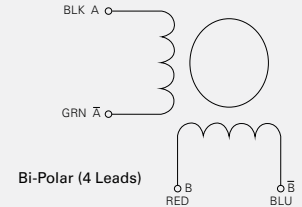

SPEED CHARTS

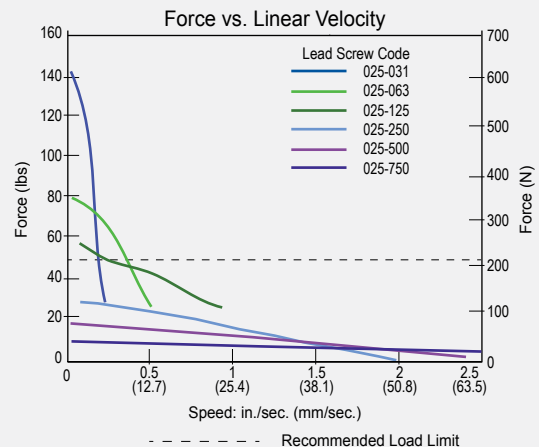
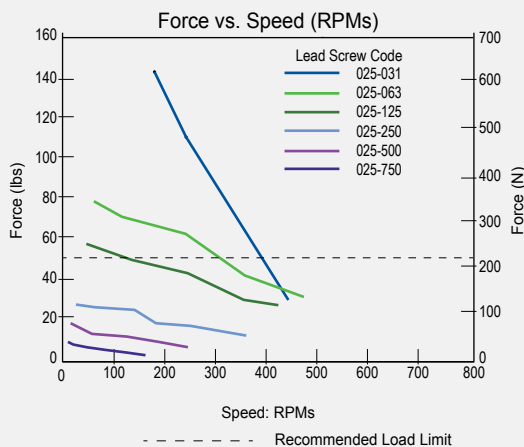



MICRO PRECISION LINEAR ACTUATORS

Modular Miniature Linear Actuators

SMA - 23

**SIZE 23 - HYBRID LINEAR ACTUATOR
(1.8° STEP ANGLE)**

MOTOR CHARACTERISTICS

Wiring	Bipolar
Operating Voltage	2.5 VDC
Current / Phase	2.5A
Resistance / Phase	1.0 ohms
Inductance / Phase	2.2 mH
Power Consumption	13 W
Temperature Rise	135° F
Weight	18 oz (511g)
Insulation Resistance	20 M Ω

NEMA 23 Hybrid Stepper Motor

