

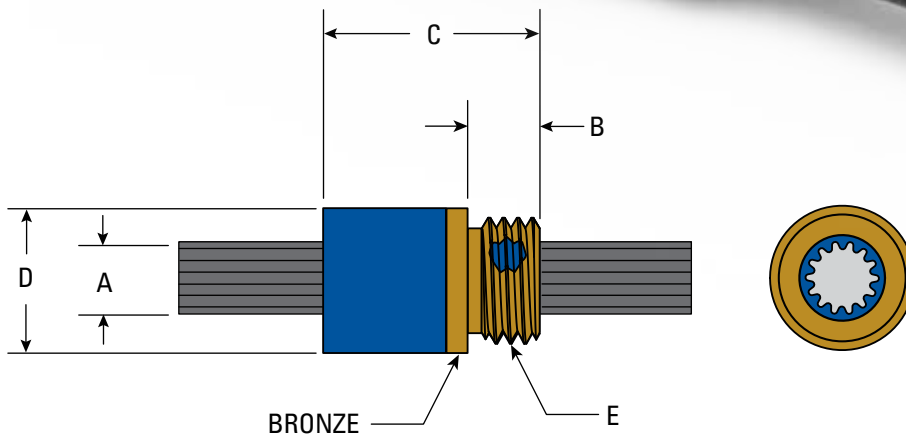

# MINIATURE PRECISION TORQUE SPLINES

## THREAD MOUNT BUSHINGS

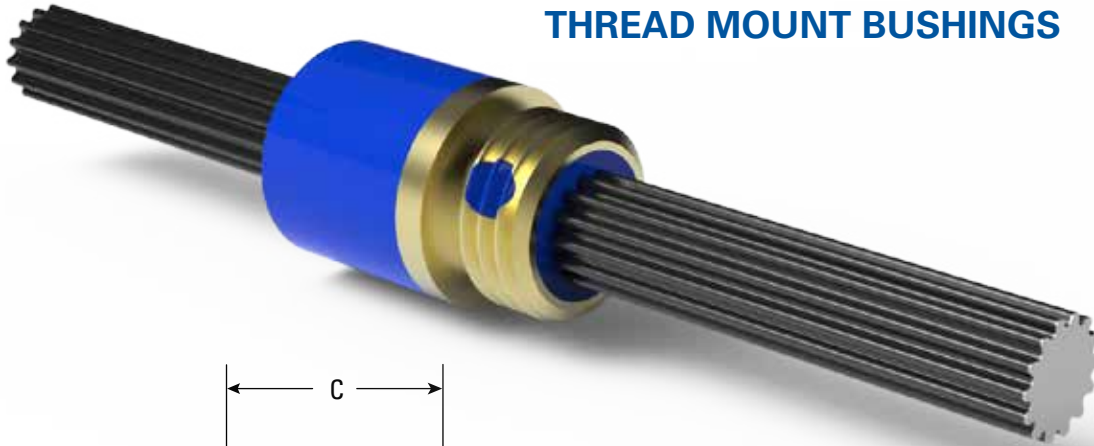

### SPECIFICATIONS

RAIL DIAMETER	(A) SHAFT DIAMETER	ROOT DIAMETER	EQUIVALENT DIAMETER	(B) THREAD LENGTH	(C) BUSHING LENGTH	(D) BUSHING DIAMETER	(E) MOUNTING THREAD
<b>Tolerances</b>	± .002" [± .05 mm]	± .002" [± .05 mm]	± .002" [± .05 mm]	± .005" [± .13 mm]	± .015" [± .38 mm]	± .001" [± .05 mm]	
<b>1/4"</b>	0.250"	0.202"	0.226"	0.235"	0.75"	0.500"	7/16-20 UNF
	6.35 mm	5.13 mm	5.74 mm	5.97 mm	19.05 mm	12.70 mm	
<b>3/8"</b>	0.375"	0.306"	0.343"	0.360"	1.00"	0.625"	9/16-20 UN
	9.53 mm	7.77 mm	8.71 mm	9.14 mm	25.40 mm	15.88 mm	
<b>1/2"</b>	0.500"	0.419"	0.460"	0.485"	1.50"	0.813"	3/4-20 UNEF
	12.70 mm	10.64 mm	11.68 mm	12.32 mm	38.10 mm	20.64 mm	