

1

2

3

4

5

6

7

A

B

C

D

Inspection Good mark
Width 2mm Min.
Length 2mm Min.

Plasma Welding
Size: $\phi 7$ Max.
2 Places

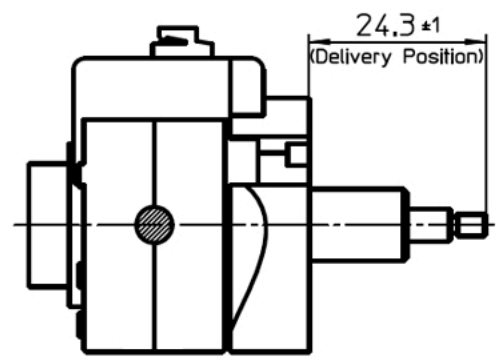
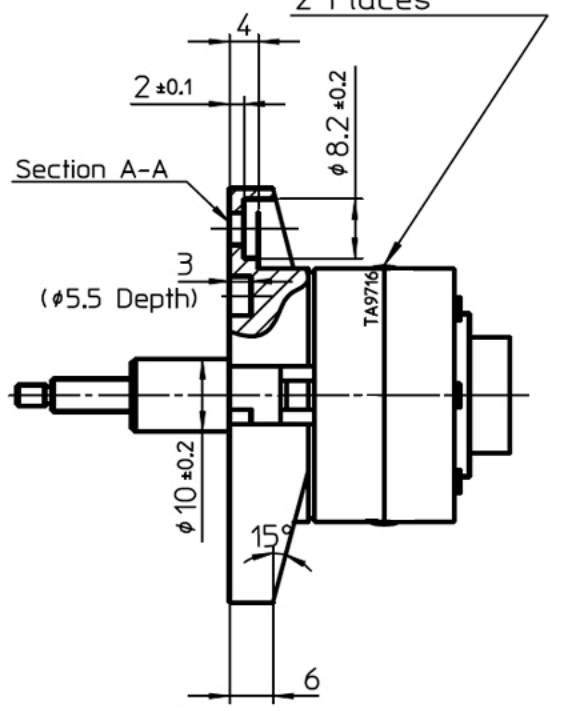
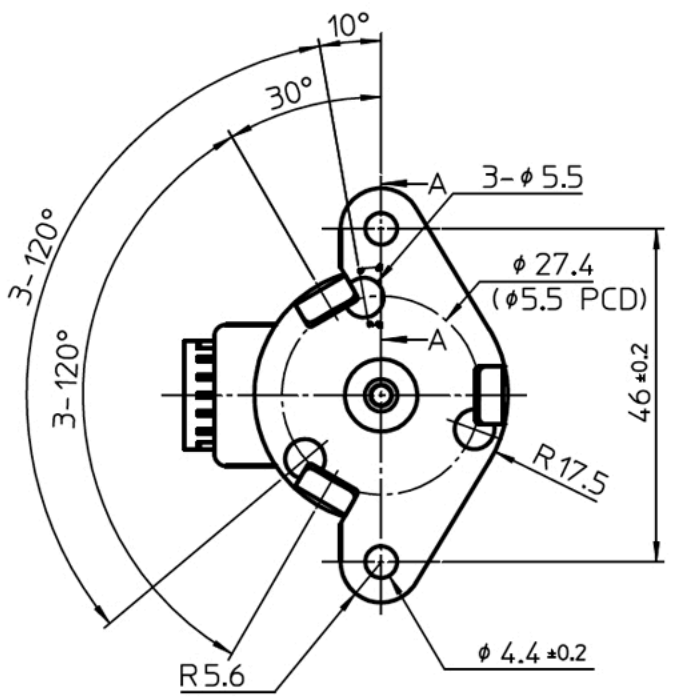
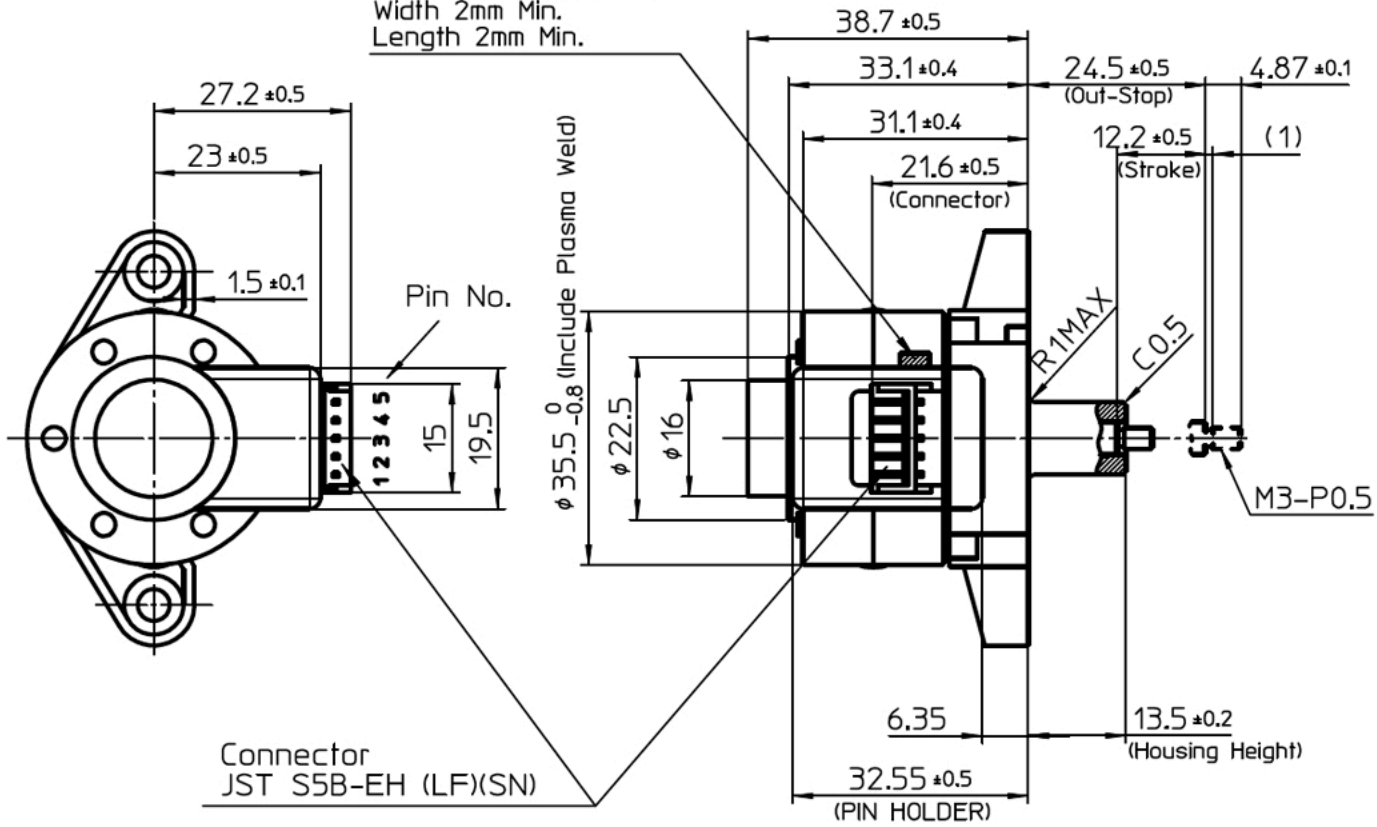

Delivery Form

Note
1. ±0.3 ±3°
No indicated tolerance shall be ±0.3mm and ±3° for angle.

Pitch / Step : 0.0333mm at 2-2 Phase on

Head Spindle In

Pin	Connector	Step			
		1	2	3	4
No.1	A1	+	-	-	+
No.2	A3	-	+	+	-
No.3	B3	+	+	-	-
No.4	B1	-	-	+	+
No.5	NC				

Head Spindle Out

Pin	Connector	Step			
		1	2	3	4
No.1	A1	+	-	-	+
No.2	A3	-	+	+	-
No.3	B3	-	-	+	+
No.4	B1	+	+	-	-
No.5	NC				

					UNIT mm		MATERIAL	DATE JUL./19/'19	
					SCALE 1 : 1			SURF.ROUGH.	DESCRIPTION MECHANICAL CONSTRUCTION
					L		HEAT TREAT.		PART NO.(MODEL NO.) CLA-35
					L ≤ 4 ±0.1			FINISH	DRAWING NO. CLA-35
					4 < L ≤ 16 ±0.2		SHEET		
					16 < L ≤ 63 ±0.3		REV.		
					63 < L ≤ 250 ±0.5				
					250 < L ≤ 1000 ±0.8				
					DEG ±0.5				
MARK	DATE	REASON	ECN NO.	ENGINEER	APPROVED	TOL			