

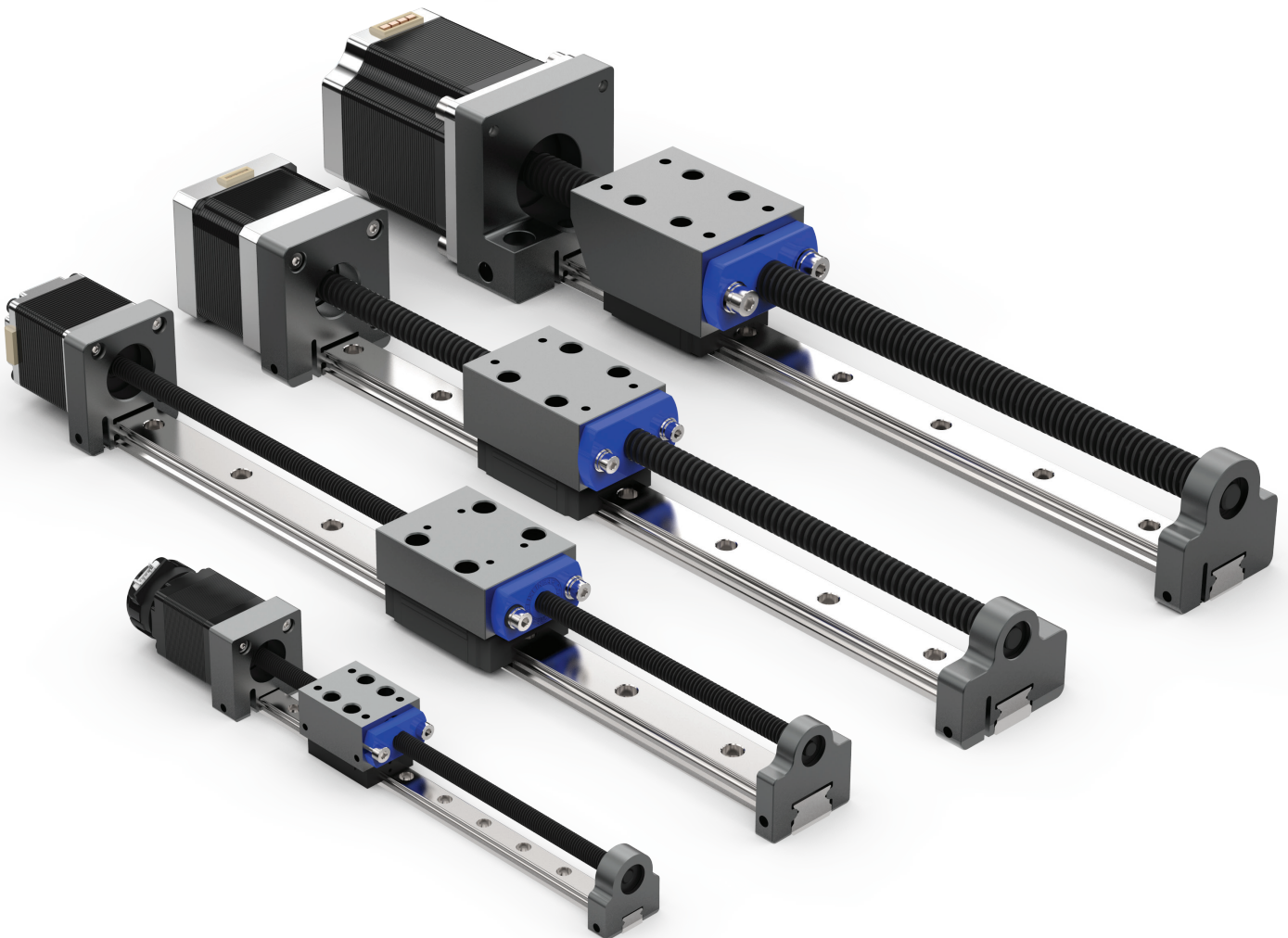

PROFILE RAIL LINEAR GUIDE SYSTEMS





Helix Linear Technologies, Inc., Beachwood, Ohio USA

Helix Linear Technologies is the most high-tech lead screw manufacturing facility globally, producing the broadest product line of any lead screw manufacturer. We offer precision rolled, milled, and ground screws in diameters from 1.6 mm to 152.4 mm and leads from .3 mm to 75 mm. When you need Acme, Trapezoidal, or high-helix lead screws with precision low-backlash nuts, or a state-of-the-art anti-backlash design, we deliver the highest quality coupled with exceptional value.

Helix Linear Technologies offers a complete line of nuts in standard, anti-backlash, or custom designs with centralizing threads to match our precision lead screws, making our assemblies the lowest backlash product on the market. Our nuts come in various materials, including Acetal, PEEK, Bronze, Ertalyte, Carbon-Filled HPV, Turcite, Torlon, Vespel, PAI, PVDF, and medical-grade Acetal to fit your specific use and environment.

CULTURE

Our culture is rooted in teamwork and consists of smart, happy, and competitive professionals focused on manufacturing innovative products and delivering precise electromechanical linear motion solutions. We are in the people business, as well as the product business. Our talented employees make and sell our products, and our extraordinary scope of teamwork keeps our company healthy.

OPERATIONS

Our company delivers high-quality products and offers world-class engineering support, solving the most demanding linear motion applications across multiple industries. We manufacture components and subsystem solutions to high volume OEMs and custom machine builders to ensuring their success.

COMPANY

Helix Linear Technologies is a global supplier in the medical device, life science, security, semiconductor, aerospace, electromechanical, and defense industries. Leading the linear motion industry by manufacturing the highest quality linear actuation solutions in the world, we focus on helping our customers be productive and profitable. Our innovative product design solves real-world linear motion issues and builds a foundation for long term success.

HISTORY

Helix Linear Technologies was founded in 2011 to meet the demand for high-quality lead screws in the growing electromechanical actuation industry. Our rapid growth has included the addition of end-to-end linear actuator solutions, providing integrated solutions.

INDEX

Company Overview	IFC
Ordering Guide	2
Lead Screw Options	3
PRA 8 Lead Screw Linear Actuator.....	4-5
PRA 11 Lead Screw Linear Actuator	6-7
PRA 17 Lead Screw Linear Actuator	8-9
PRA 23 Lead Screw Linear Actuator.....	10-11
Stepper Motor, Encoder, H10X, Screw and Nut Options.....	12
Custom Solutions	13-14
Performance Charts.....	16
Buckle Column Loads.....	17

PARTNERS



CERTIFICATIONS



Helix Linear Technologies' Profile Rail Linear Guide Systems feature smooth, clean, quiet linear positioning. These compact assemblies are built with a 300 series stainless steel precision lead screw coated with Helix H10X™ PTFE dry lubricant, extending the lead screw nut life by up to ten times. The lead screw assembly incorporates a standard or anti-backlash nut to eliminate axial and radial lash.

The profile rail linear guide system utilizes a precision high-accuracy profile rail to deliver pitch, roll, and yaw guidance. These low-profile, compact, pre-assembled linear actuators offer an economical turn-key linear motion solution.

PROFILE RAIL LINEAR GUIDE SYSTEM - ORDERING GUIDE

PRA	8	S	5	025	N	10	E200	A
Series	Series Model	Motor Length	Voltage	Lead Code	Nut Style	Series	Encoder	Encoder Position
PRA Profile Rail Linear Actuator	8	S Single Stack	See product page for rated voltage availability	See Lead Code Table Pg. 3	N Standard Free-wheeling Nut	Length (inch) example: 10.00"	E 200 200 CPR	A
	11	S Single Stack or D Double Stack					E 500 500 CPR	
	17				E 1000 1000 CPR			
	23				A Axial Anti-Backlash Nut		E 2000 2000 CPR <i>Not available for size 8.</i>	B
						00 No Encoder	0 No Encoder Position	

We welcome custom projects. To speak with one of our linear motion project engineers, email us at engineeringhelp@helixlinear.com or call 1-855-435-4958.

ENCODER POSITION DIAGRAM

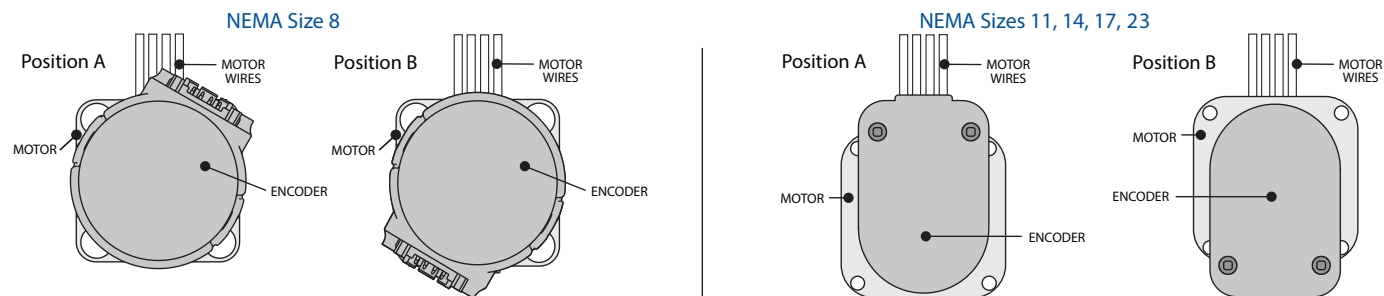

LEAD SCREW OPTIONS

PRA-8

Screw Diameter	Diameter Code	Lead	Lead Code	Efficiency %
0.1875	018	0.0240	024	32
0.1875	018	0.0250	025	33
0.1875	018	0.0313	031	38
0.1875	018	0.0394	039	43
0.1875	018	0.0480	048	48
0.1875	018	0.0500	050	49
0.1875	018	0.0625	062	55
0.1875	018	0.0787	078	60
0.1875	018	0.0960	096	64
0.1875	018	0.1000	100	65
0.1875	018	0.1250	125	70
0.1875	018	0.1575	157	74
0.1875	018	0.200	200	77

PRA11

Screw Diameter	Diameter Code	Lead	Lead Code	Efficiency %
0.250	025	0.0250	025	25
0.250	025	0.0393	039	39
0.250	025	0.0500	050	46
0.250	025	0.0625	062	53
0.250	025	0.0787	078	56
0.250	025	0.1000	100	62
0.250	025	0.1250	125	68
0.250	025	0.2000	200	75
0.250	025	0.2500	250	79
0.250	025	0.3330	333	82
0.250	025	0.5000	500	84
0.250	025	0.7500	750	81
0.250	025	1.0000	999	82

PRA17

Screw Diameter	Diameter Code	Lead	Lead Code	Efficiency %
0.375	037	0.050	050	35
0.375	037	0.078	078	47
0.375	037	0.100	100	55
0.375	037	0.157	157	63
0.375	037	0.196	196	67
0.375	037	0.200	200	70
0.375	037	0.250	250	73
0.375	037	0.375	375	78
0.375	037	0.400	400	80
0.375	037	0.500	500	82
0.375	037	0.750	750	84
0.375	037	1.000	999	84
0.375	037	1.500	M38	83

PRA23

Screw Diameter	Diameter Code	Lead	Lead Code	Efficiency %
0.500	050	0.0500	050	28
0.500	050	0.1000	100	47
0.500	050	0.5000	500	79
0.500	050	0.8000	800	83
0.500	050	1.0000	999	84
0.500	050	0.2500	250	69

NEMA 8 - Single Stack

Profile Rail Linear Guide System (PRA)

Lead Screw
Single Stack
1.8° Step Angle

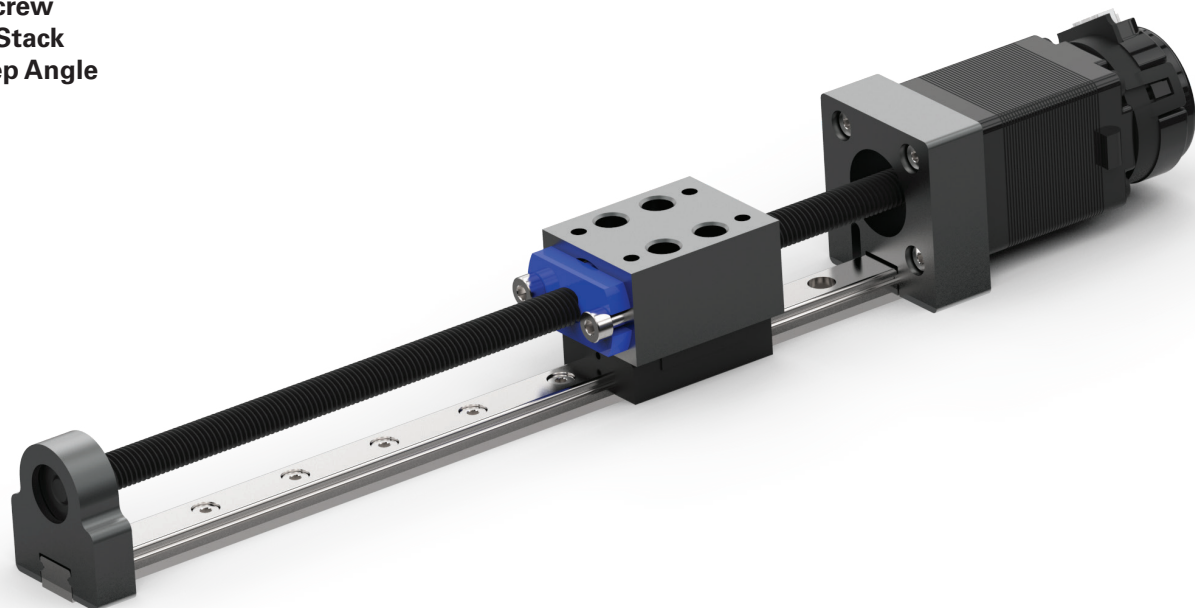

Motor Characteristics

Wiring	Rated Voltage (V)	Rated Current (A)	Resistance /Phase (Ω)	Inductance /Phase (mH)	Power Consumption (W)	Temperature Rise (° F)	Weight (oz)	Insulation Resistance (MΩ)
Bi-Polar	2.5	0.49	5.1	1.5	2.45	167	1.5	20
	5	0.24	20.4	5.0				
	7.5	0.16	45.9	11.7				

Available Lead Screws

Model	Screw Diameter	Lead	Pitch	Travel Per Step	L Minimum (in)	L Maximum (in)
PRA-8S-024	0.1875	0.0240	0.0240	0.0001200	Travel + 1.9"	5" Longer custom order lengths available. Contact sales for details.
PRA-8S-025	0.1875	0.0250	0.0250	0.0001250		
PRA-8S-031	0.1875	0.0313	0.0313	0.0001565		
PRA-8S-039	0.1875	0.0394	0.0394	0.0001970		
PRA-8S-048	0.1875	0.0480	0.0480	0.0002400		
PRA-8S-050	0.1875	0.0500	0.0500	0.0002500		
PRA-8S-062	0.1875	0.0625	0.0313	0.0003125		
PRA-8S-078	0.1875	0.0787	0.0394	0.0003935		
PRA-8S-096	0.1875	0.0960	0.0480	0.0004800		
PRA-8S-100	0.1875	0.1000	0.0500	0.0005000		
PRA-8S-125	0.1875	0.1250	0.0313	0.0006250		
PRA-8S-157	0.1875	0.1575	0.0394	0.0007875		
PRA-8S-200	0.1875	0.2000	0.0500	0.0010000		

Wiring Diagram

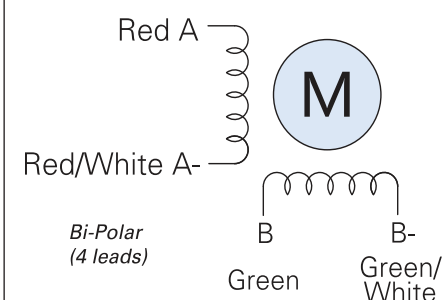

NEMA 8 - Single Stack Specifications

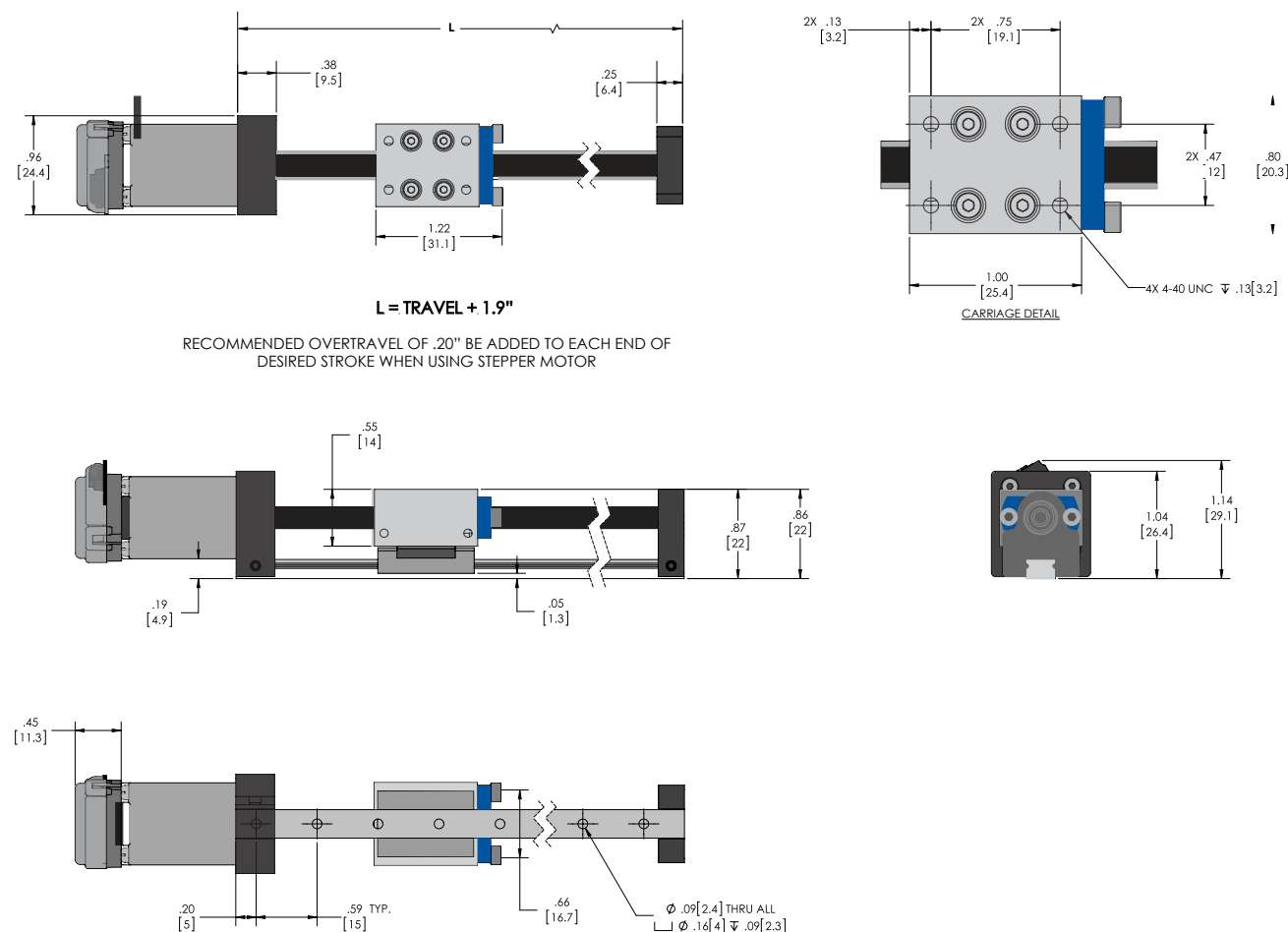

Force/Speed Charts

Force vs. Speed

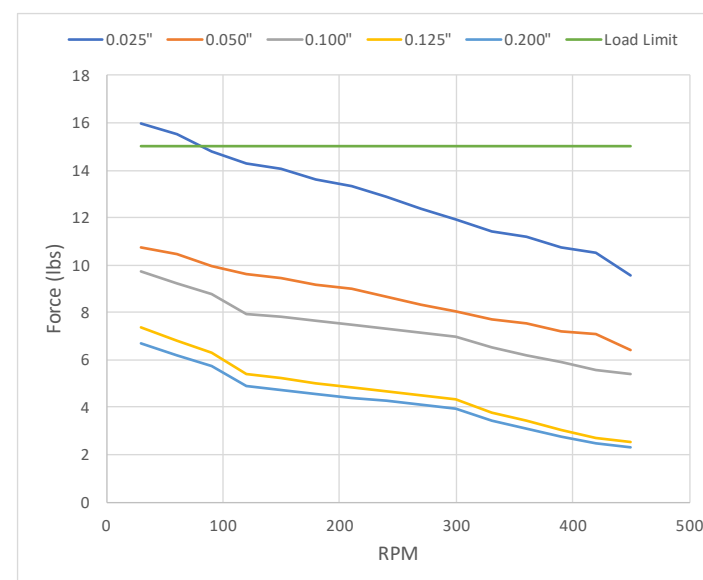

Force vs. Linear Velocity

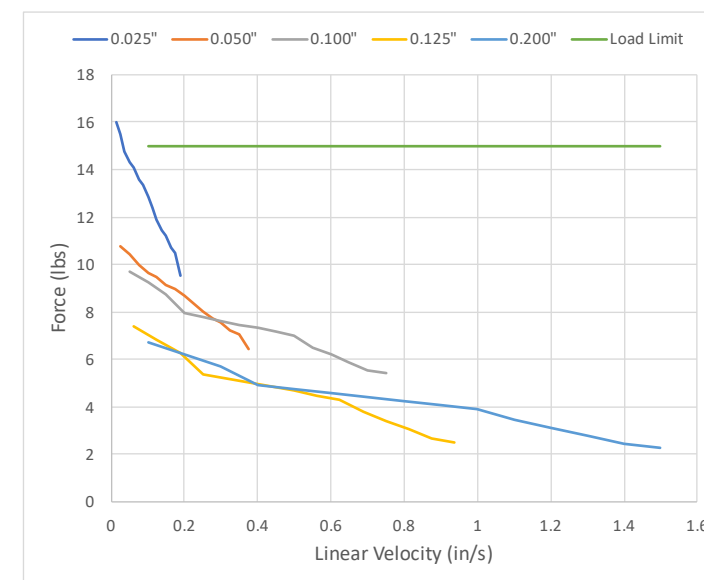

NEMA 11 - Single Stack

Profile Rail Linear Guide System (PRA)

Lead Screw

1.8° Step Angle

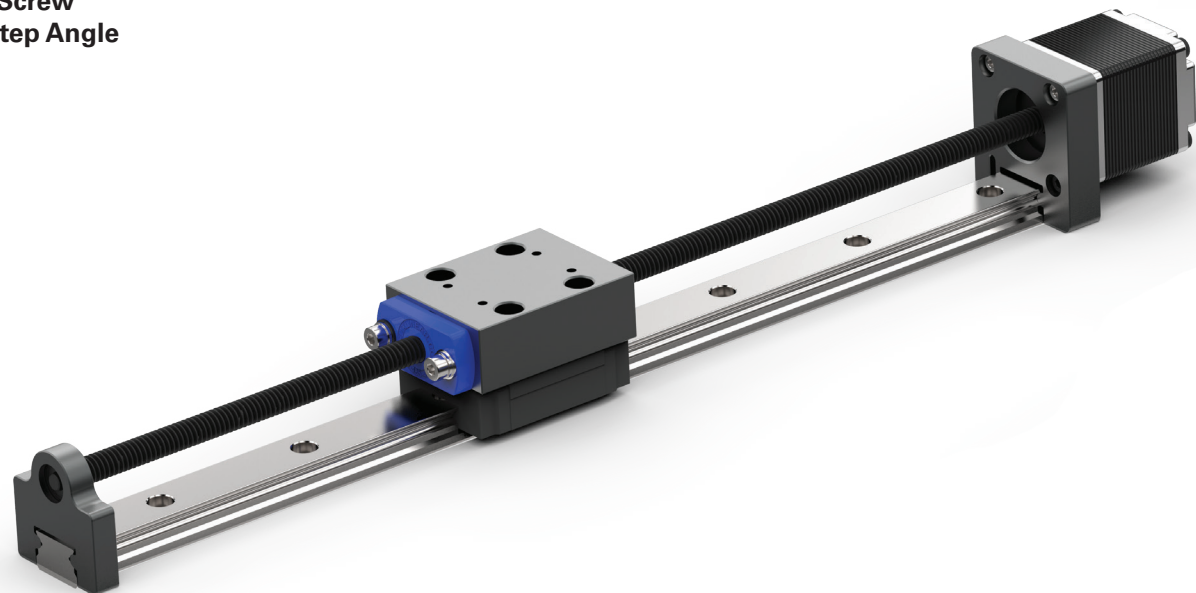

Motor Characteristics

Wiring	Rated Voltage (V)	Rated Current (A)	Resistance /Phase (Ω)	Inductance /Phase (mH)	Power Consumption (W)	Temperature Rise (° F)	Weight (oz)	Insulation Resistance (MΩ)
Bi-Polar	2.1	1.0	2.1	1.5	4.2	167	4.20	20
	5	0.42	11.9	6.7				
	12	0.18	68.6	39				

Available Lead Screws

Model	Screw Diameter	Lead	Pitch	Travel Per Step	L Minimum (in)	L Maximum (in)
PRA-11-025	0.250	0.0250	0.0625	0.0001250	Travel + 2.6	12.0 <i>Longer custom order lengths available. Contact sales for details.</i>
PRA-11-039	0.250	0.0393	0.0394	0.0001965		
PRA-11-050	0.250	0.0500	0.0500	0.0002500		
PRA-11-062	0.250	0.0625	0.0625	0.0003125		
PRA-11-078	0.250	0.0787	0.0394	0.0003935		
PRA-11-100	0.250	0.1000	0.0500	0.0005000		
PRA-11-125	0.250	0.1250	0.0625	0.0006250		
PRA-11-200	0.250	0.2000	0.0500	0.0010000		
PRA-11-250	0.250	0.2500	0.0625	0.0012500		
PRA-11-330	0.250	0.3300	0.0833	0.0016650		
PRA-11-500	0.250	0.5000	0.1250	0.0025000		
PRA-11-750	0.250	0.7500	0.0625	0.0037500		
PRA-11-999	0.250	1.0000	0.1000	0.0050000		

Wiring Diagram

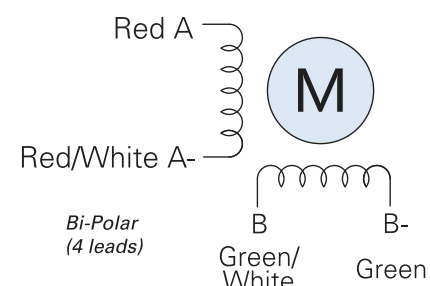

NEMA 11 - Single Stack Specifications

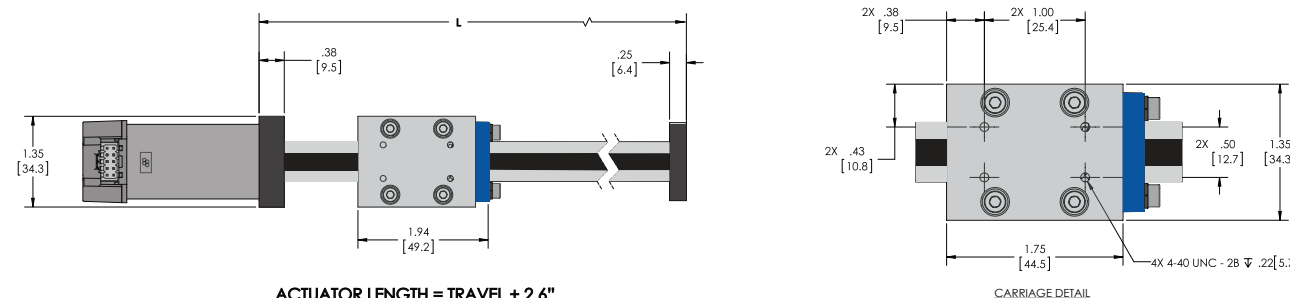

ACTUATOR LENGTH = TRAVEL + 2.6"

RECOMMENDED OVERTRAVEL OF .39" BE ADDED TO EACH END OF DESIRED STROKE WHEN USING STEPPER MOTOR

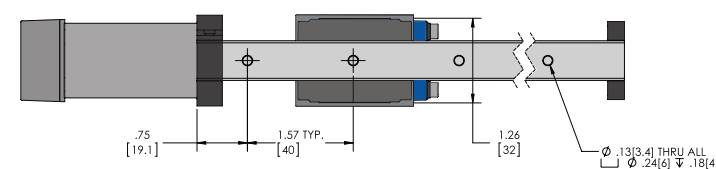
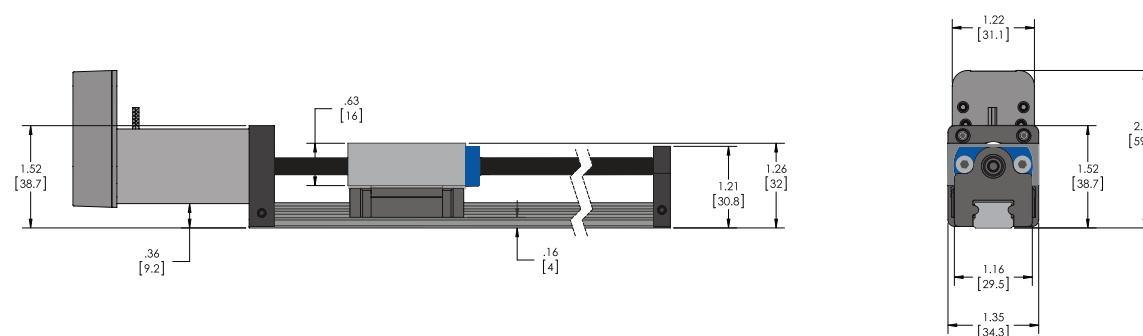

Force/Speed Charts

Force vs. Speed

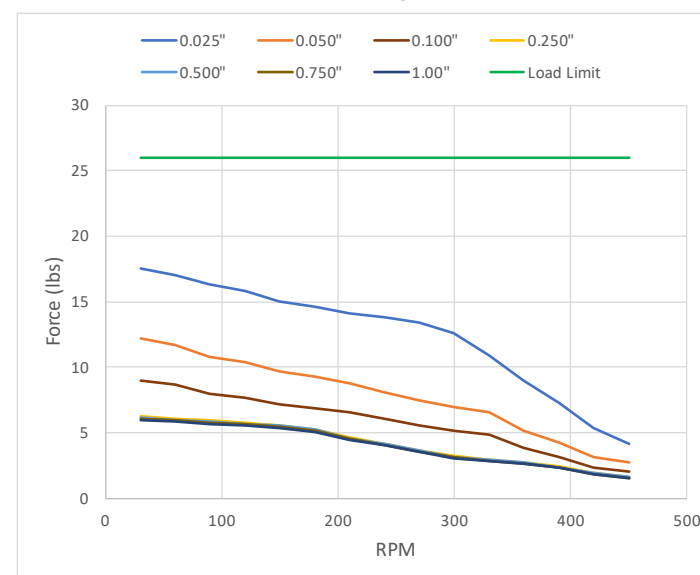

Force vs. Linear Velocity

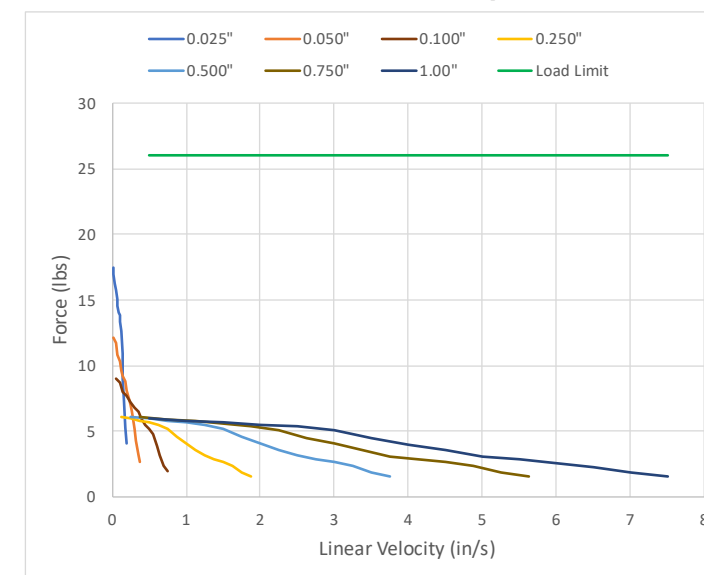

NEMA 11 - Double Stack Profile Rail Linear Guide System (PRA)

Lead Screw
1.8° Step Angle

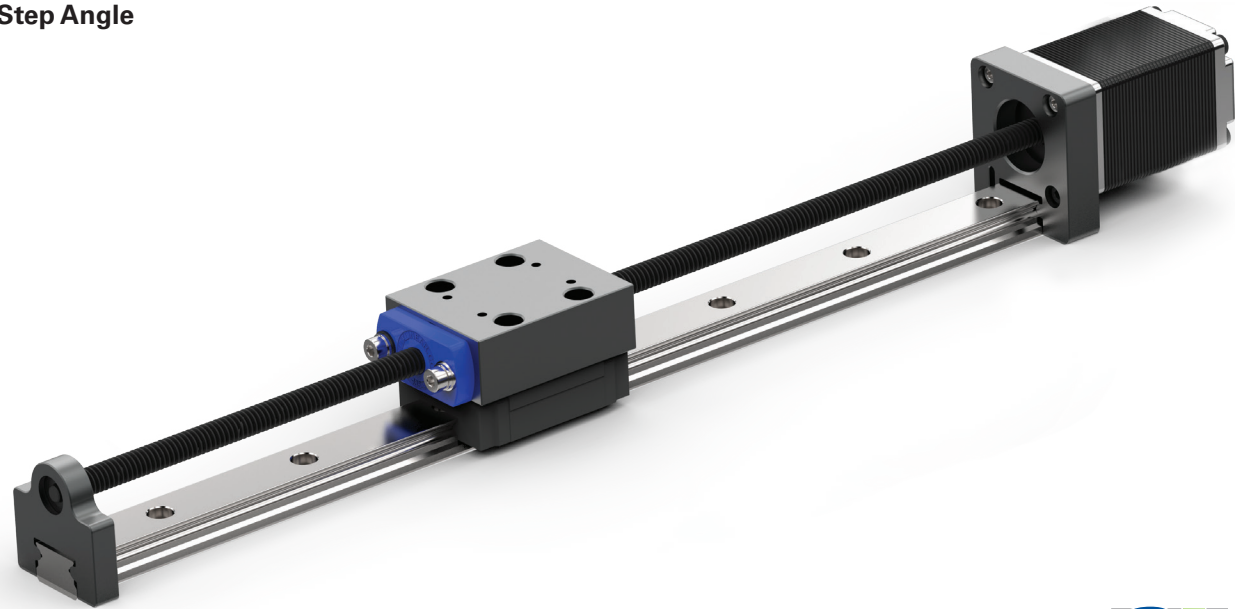

Motor Characteristics								
Wiring	Rated Voltage (V)	Rated Current (A)	Resistance /Phase (Ω)	Inductance /Phase (mH)	Power Consumption (W)	Temperature Rise (° F)	Weight (oz)	Insulation Resistance (MΩ)
Bi-Polar	2.1	1.9	1.1	1.1	75	167	6.35	20
	5	0.75	6.7	5.8				
	12	0.35	34.8	35.6				

Available Lead Screws						
Model	Screw Diameter	Lead	Pitch	Travel Per Step	L Minimum (in)	L Maximum (in)
PRA-11-025	0.250	0.0250	0.0625	0.0001250	Travel + 2.6	12.0 <i>Longer custom order lengths available. Contact sales for details.</i>
PRA-11-039	0.250	0.0393	0.0394	0.0001965		
PRA-11-050	0.250	0.0500	0.0500	0.0002500		
PRA-11-062	0.250	0.0625	0.0625	0.0003125		
PRA-11-078	0.250	0.0787	0.0394	0.0003935		
PRA-11-100	0.250	0.1000	0.0500	0.0005000		
PRA-11-125	0.250	0.1250	0.0625	0.0006250		
PRA-11-200	0.250	0.2000	0.0500	0.0010000		
PRA-11-250	0.250	0.2500	0.0625	0.0012500		
PRA-11-330	0.250	0.3300	0.0833	0.0016650		
PRA-11-500	0.250	0.5000	0.1250	0.0025000		
PRA-11-750	0.250	0.7500	0.0625	0.0037500		
PRA-11-999	0.250	1.0000	0.1000	0.0050000		

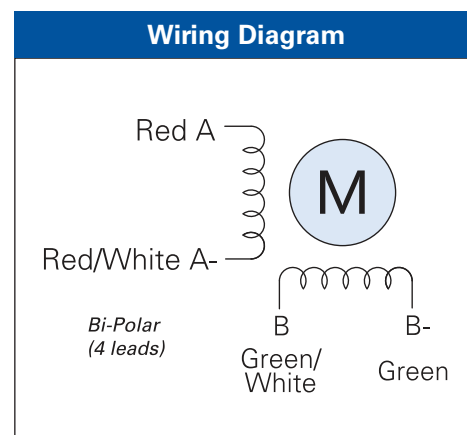

NEMA 11 - Double Stack Specifications

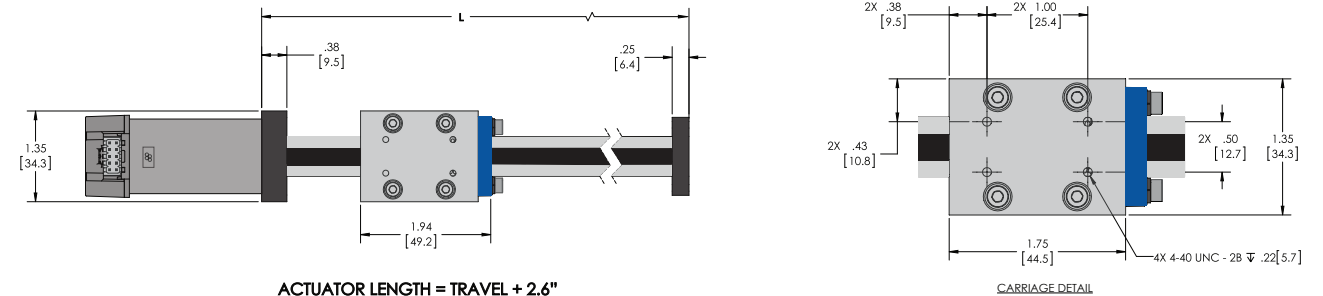

ACTUATOR LENGTH = TRAVEL + 2.6"
RECOMMENDED OVERTRAVEL OF .39" BE ADDED TO EACH END OF DESIRED STROKE WHEN USING STEPPER MOTOR

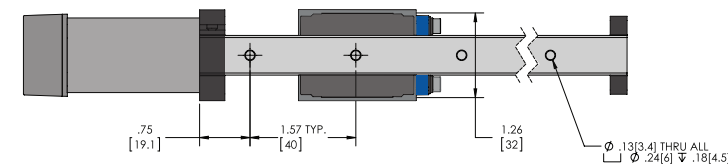
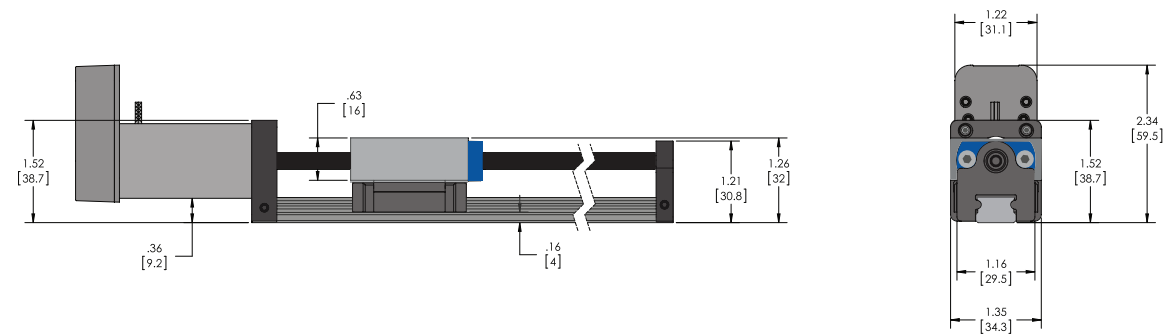

Force/Speed Charts

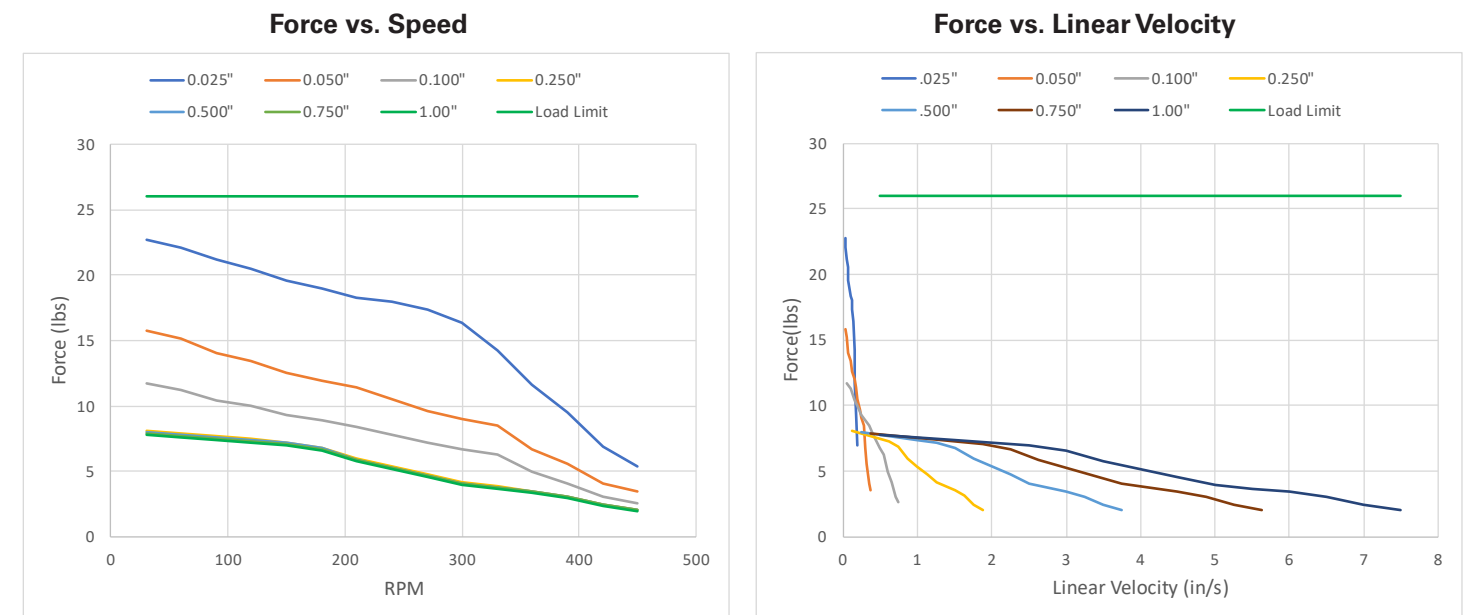

NEMA 17 - Single Stack

Profile Rail Linear Guide System (PRA)

Lead Screw
1.8° Step Angle

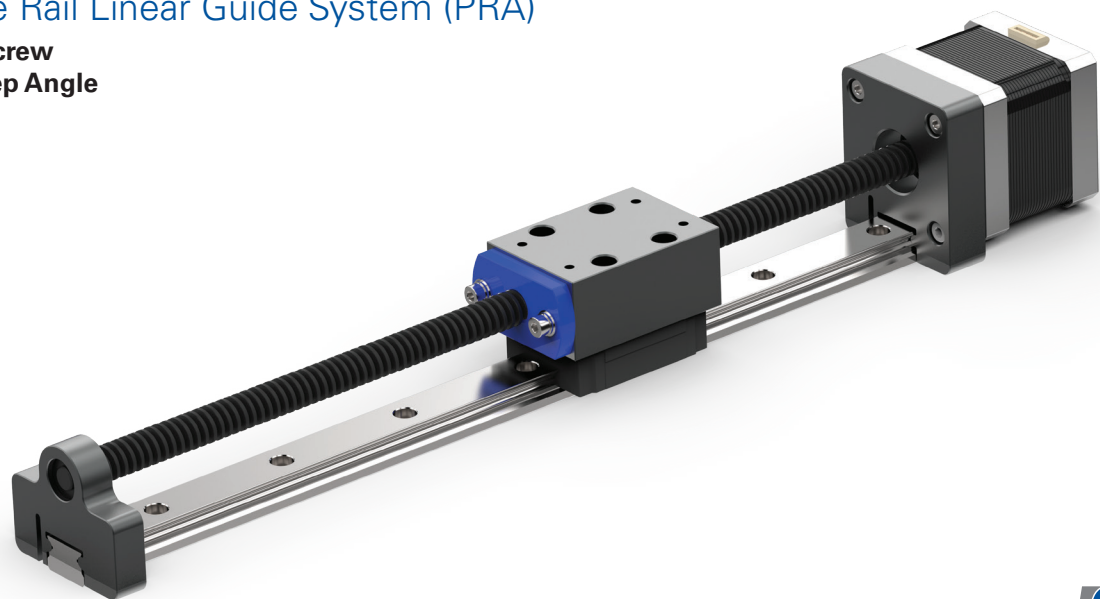

Motor Characteristics

Wiring	Rated Voltage (V)	Rated Current (A)	Resistance /Phase (Ω)	Inductance /Phase (mH)	Power Consumption (W)	Temperature Rise (° F)	Weight (oz)	Insulation Resistance (MΩ)
Bi-Polar	2.33	1.5	1.56	1.9	7	167	8.50	20
	5	0.7	7.2	10.6				
	12	0.29	41.5	73.3				

Available Lead Screws

Model	Screw Diameter	Lead	Pitch	Travel Per Step	L Minimum (in)	L Maximum (in)
PRA-17-050	0.375	0.050	0.050	0.000250	Travel + 3.0	18.0
PRA-17-078	0.375	0.078	0.078	0.000390		
PRA-17-100	0.375	0.100	0.100	0.000500		
PRA-17-157	0.375	0.157	0.079	0.000785		
PRA-17-196	0.375	0.196	0.039	0.000980		
PRA-17-200	0.375	0.200	0.100	0.001000		
PRA-17-250	0.375	0.250	0.063	0.001250		
PRA-17-375	0.375	0.375	0.094	0.001875		
PRA-17-400	0.375	0.400	0.100	0.002000		
PRA-17-500	0.375	0.500	0.125	0.002500		
PRA-17-750	0.375	0.750	0.063	0.003750		
PRA-17-999	0.375	1.000	0.200	0.005000		
PRA-17-M31	0.375	1.200	0.200	0.006000		
PRA-17-M38	0.375	1.500	0.167	0.007500		

Longer custom order lengths available. Contact sales for details.

Wiring Diagram

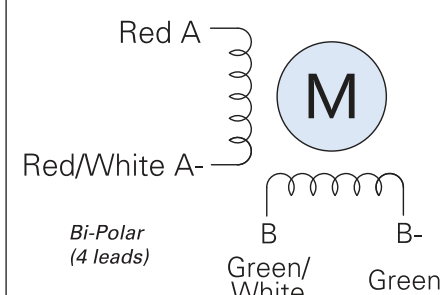

NEMA 17 - Single Stack Specifications

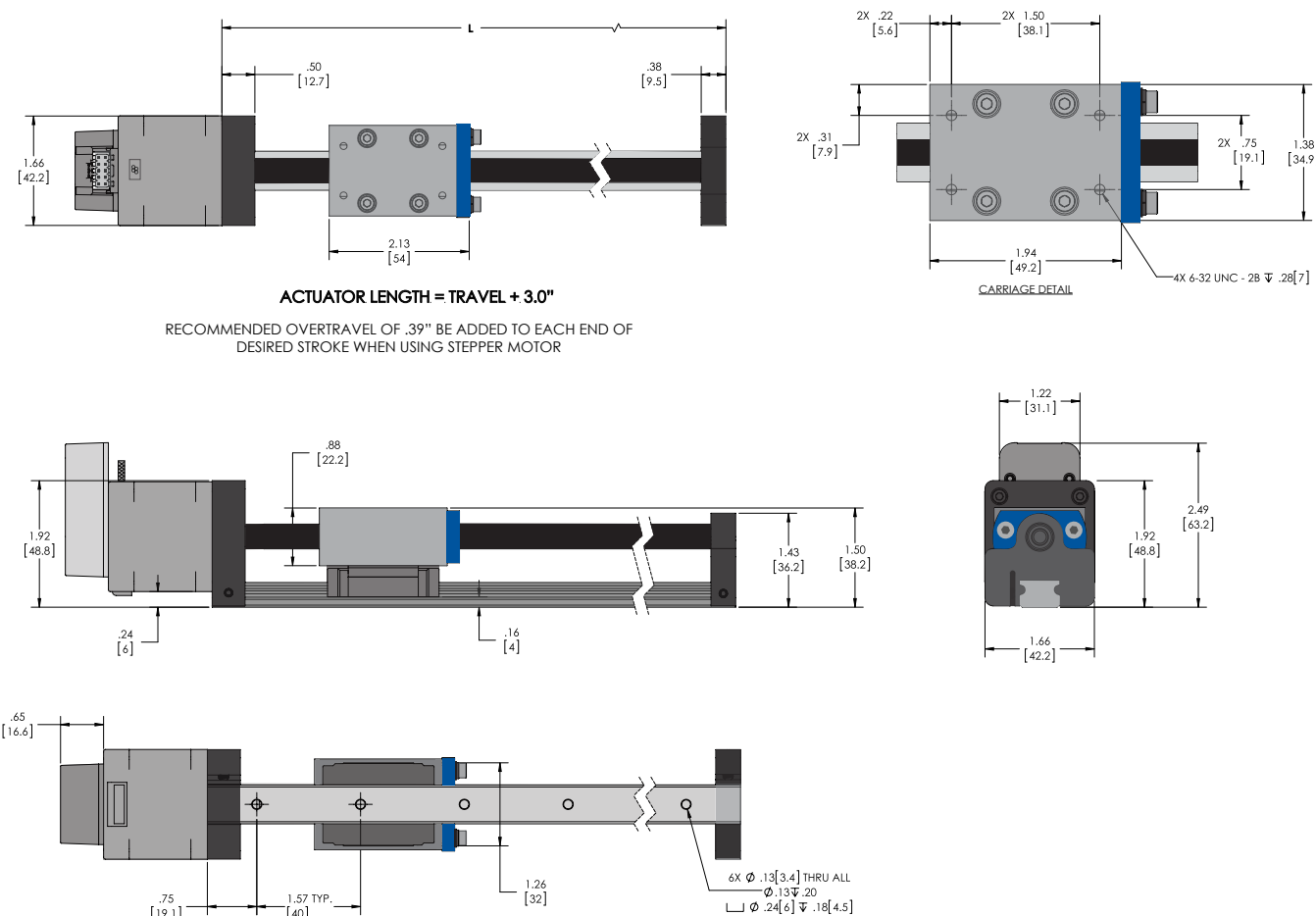

Force/Speed Charts

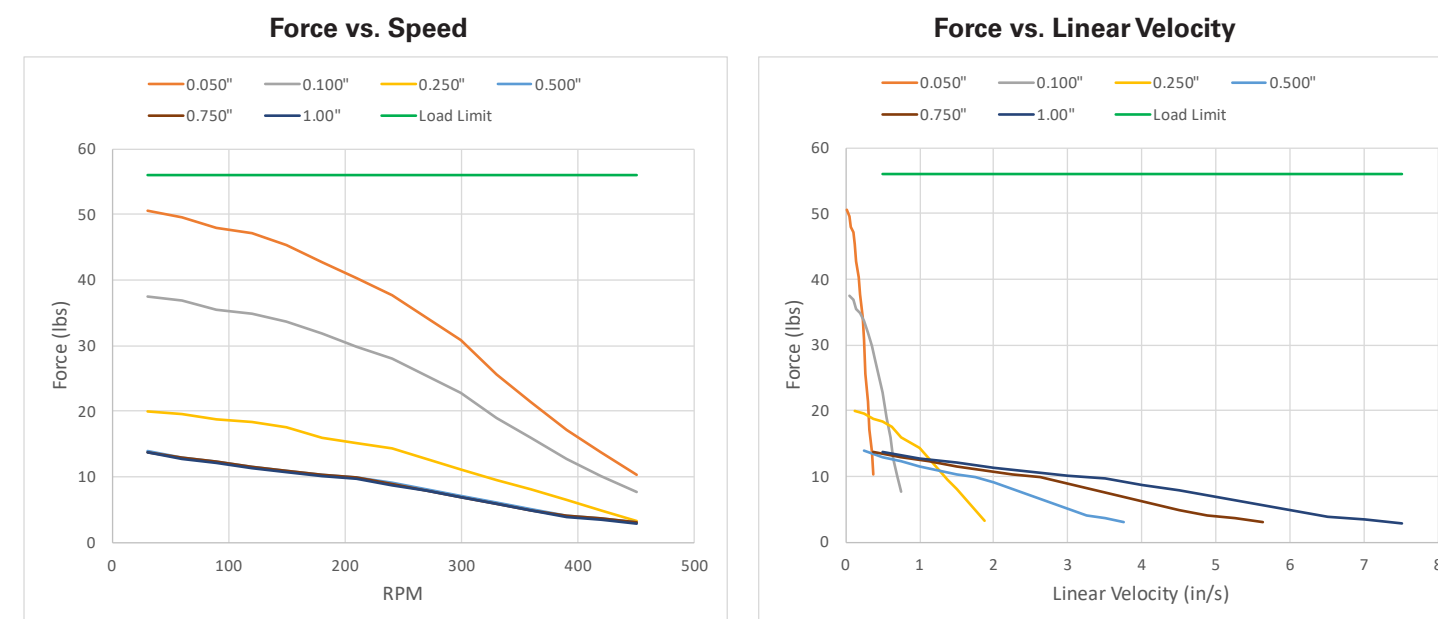

NEMA 17 - Double Stack Profile Rail Linear Guide System (PRA)

**Lead Screw
1.8° Step Angle**



Motor Characteristics

Wiring	Rated Voltage (V)	Rated Current (A)	Resistance /Phase (Ω)	Inductance /Phase (mH)	Power Consumption (W)	Temperature Rise (° F)	Weight (oz)	Insulation Resistance (MΩ)
Bi-Polar	2.33	1.5	1.56	1.9	7	167	8.50	20
	5	0.7	7.2	10.6				
	12	0.29	41.5	73.3				

Available Lead Screws

Model	Screw Diameter	Lead	Pitch	Travel Per Step	L Minimum (in)	L Maximum (in)
PRA-17-050	0.375	0.050	0.050	0.000250	Travel + 3.0	18.0
PRA-17-078	0.375	0.078	0.078	0.000390		
PRA-17-100	0.375	0.100	0.100	0.000500		
PRA-17-157	0.375	0.157	0.079	0.000785		
PRA-17-196	0.375	0.196	0.039	0.000980		
PRA-17-200	0.375	0.200	0.100	0.001000		
PRA-17-250	0.375	0.250	0.063	0.001250		
PRA-17-375	0.375	0.375	0.094	0.001875		
PRA-17-400	0.375	0.400	0.100	0.002000		
PRA-17-500	0.375	0.500	0.125	0.002500		
PRA-17-750	0.375	0.750	0.063	0.003750		
PRA-17-999	0.375	1.000	0.200	0.005000		
PRA-17-M31	0.375	1.200	0.200	0.006000		
PRA-17-M38	0.375	1.500	0.167	0.007500		

Longer custom order lengths available. Contact sales for details.

Wiring Diagram

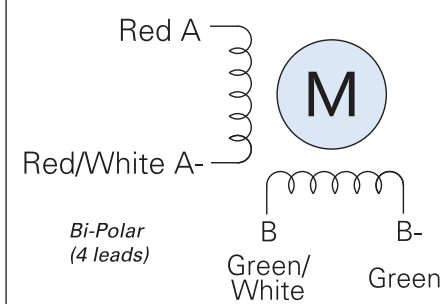

NEMA 17 - Double Stack Specifications

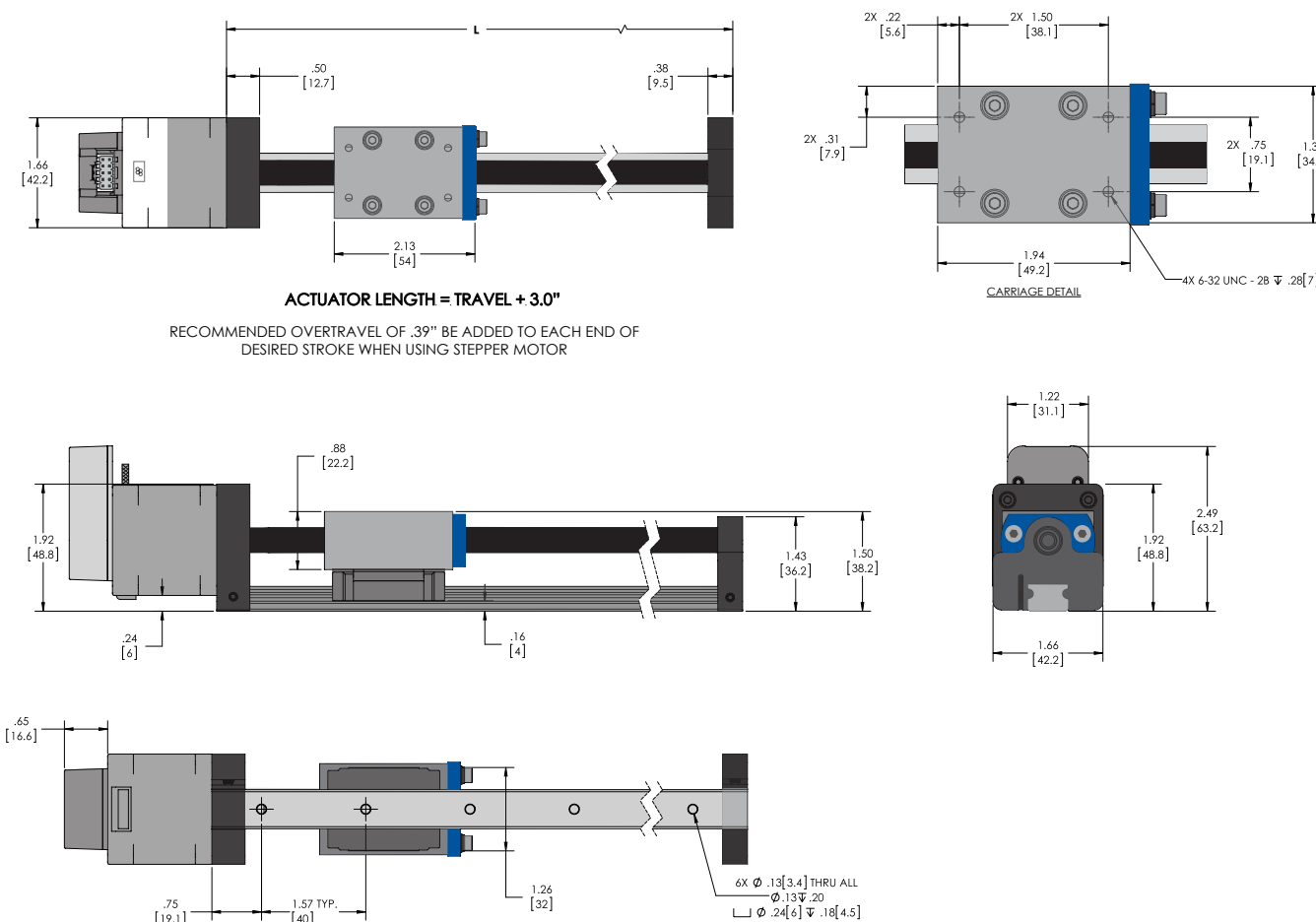

Force/Speed Charts

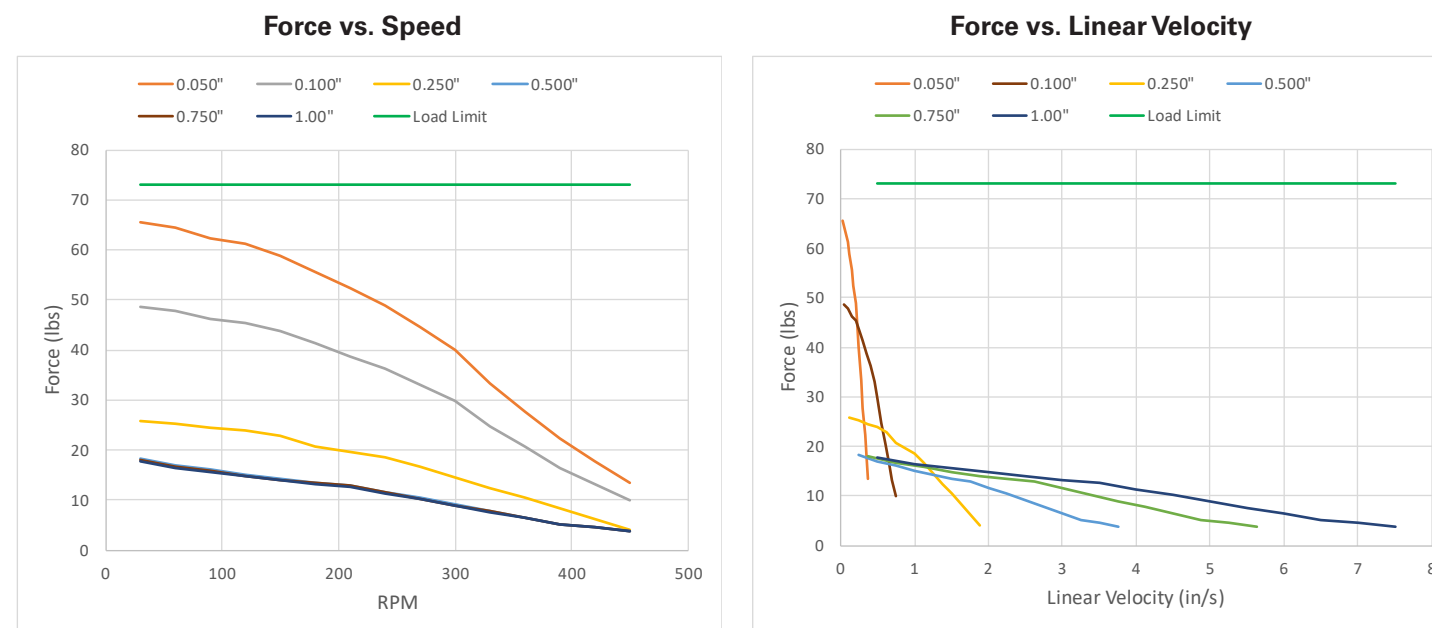

NEMA 23 - Single Stack

Profile Rail Linear Guide System (PRA)

Lead Screw
1.8° Step Angle

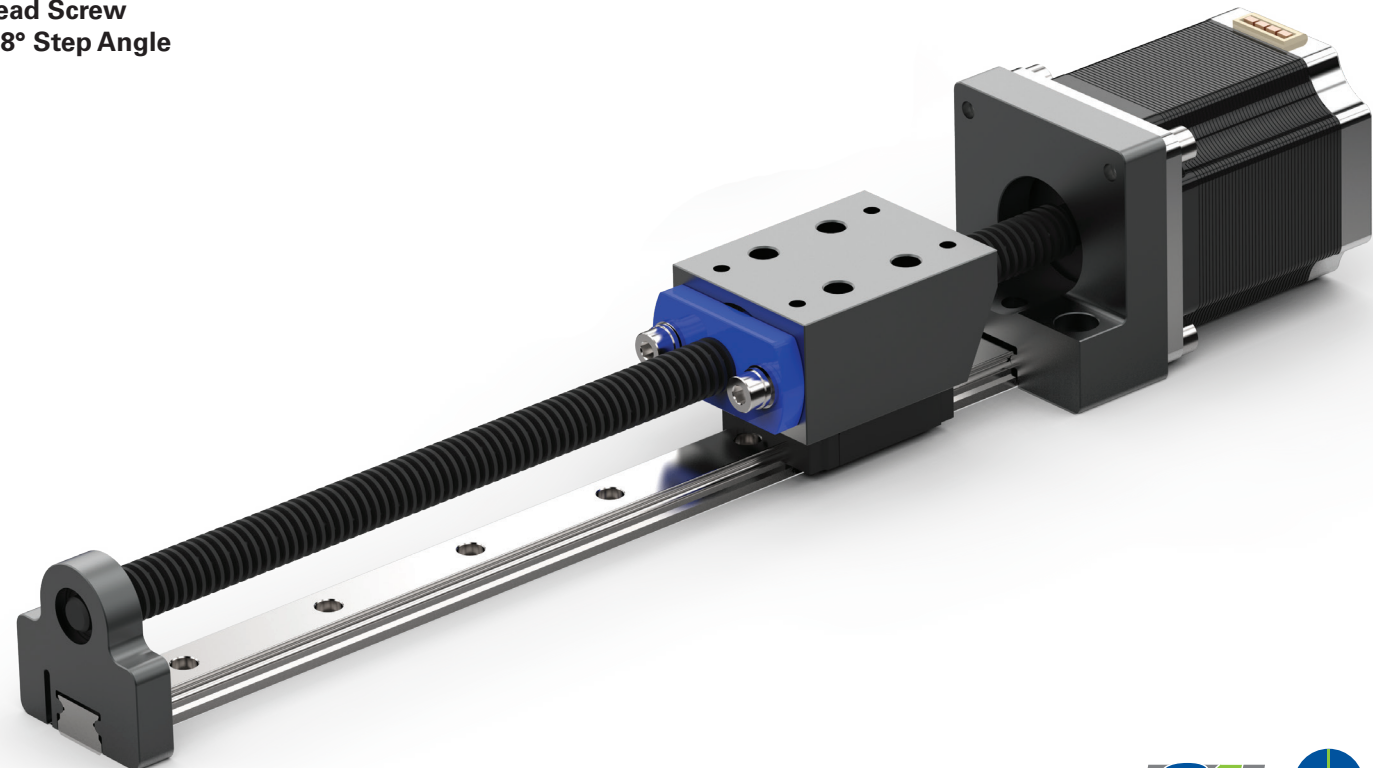

Motor Characteristics

Wiring	Rated Voltage (V)	Rated Current (A)	Resistance /Phase (Ω)	Inductance /Phase (mH)	Power Consumption (W)	Temperature Rise (° F)	Weight (oz)	Insulation Resistance (MΩ)
Bi-Polar	3.25	2	1.63	3.5	13	167	18.03	20
	5	1.3	3.85	10.5				
	12	0.54	22.2	47				

Available Lead Screws

Model	Screw Diameter	Lead	Pitch	Travel Per Step	L Minimum (in)	L Maximum (in)
PRA-23-098	0.500	0.0980	0.0980	0.00049	Travel + 3.7	24 <i>Longer custom order lengths available. Contact sales for details.</i>
PRA-23-100	0.500	0.1000	0.1000	0.00050		
PRA-23-250	0.500	0.2500	0.1250	0.00125		
PRA-23-200	0.500	0.2000	0.1000	0.00100		
PRA-23-500	0.500	0.5000	0.1000	0.00250		
PRA-23-800	0.500	0.8000	0.1000	0.00400		
PRA-23-999	0.500	1.0000	0.1250	0.00500		

Wiring Diagram

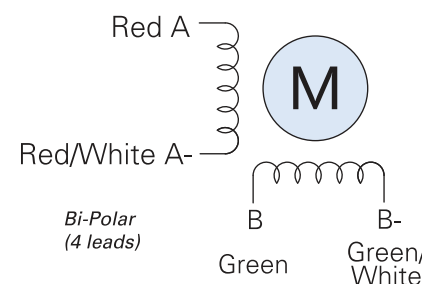

NEMA 23 - Single Stack Specifications

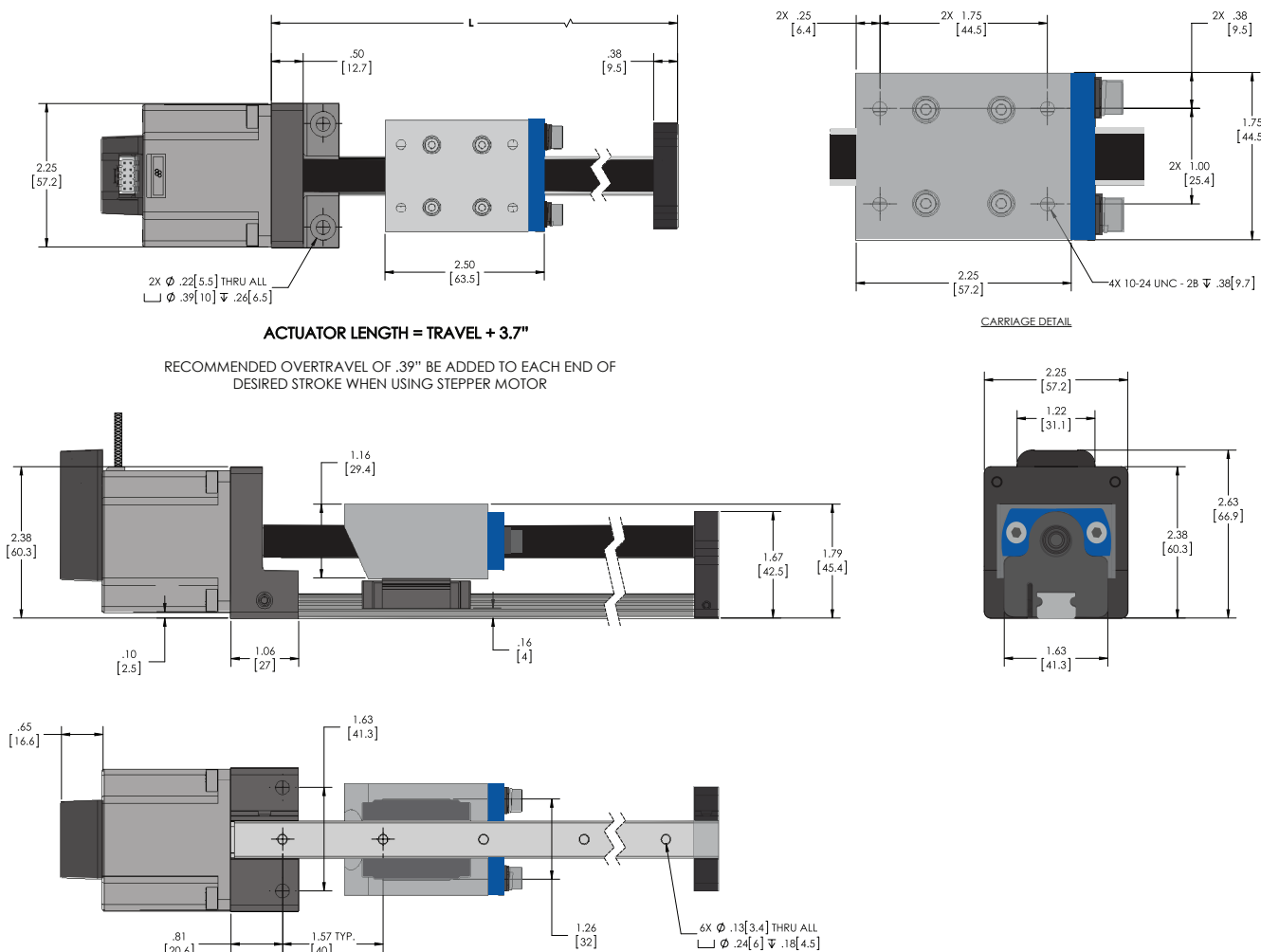

Force/Speed Charts

Force vs. Speed

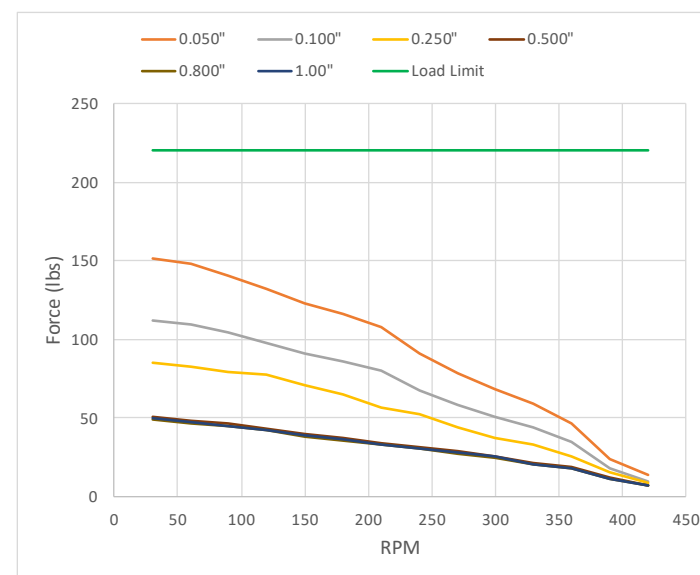

Force vs. Linear Velocity

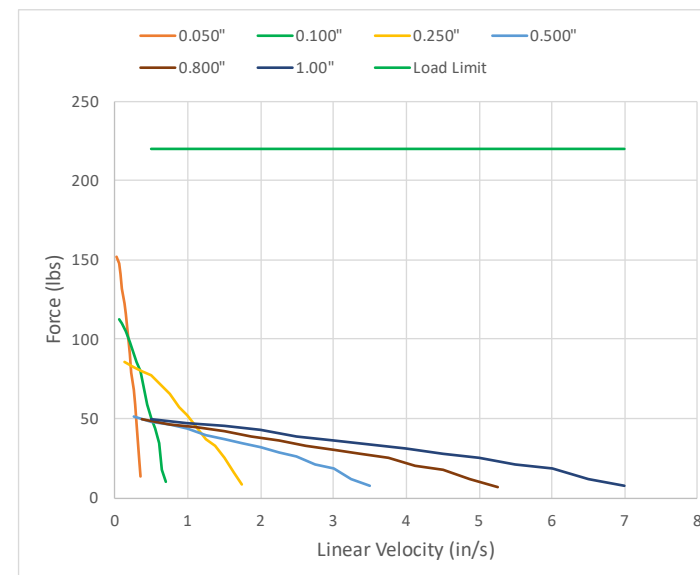

NEMA 23 - Double Stack

Profile Rail Linear Guide System (PRA)

Lead Screw
1.8° Step Angle

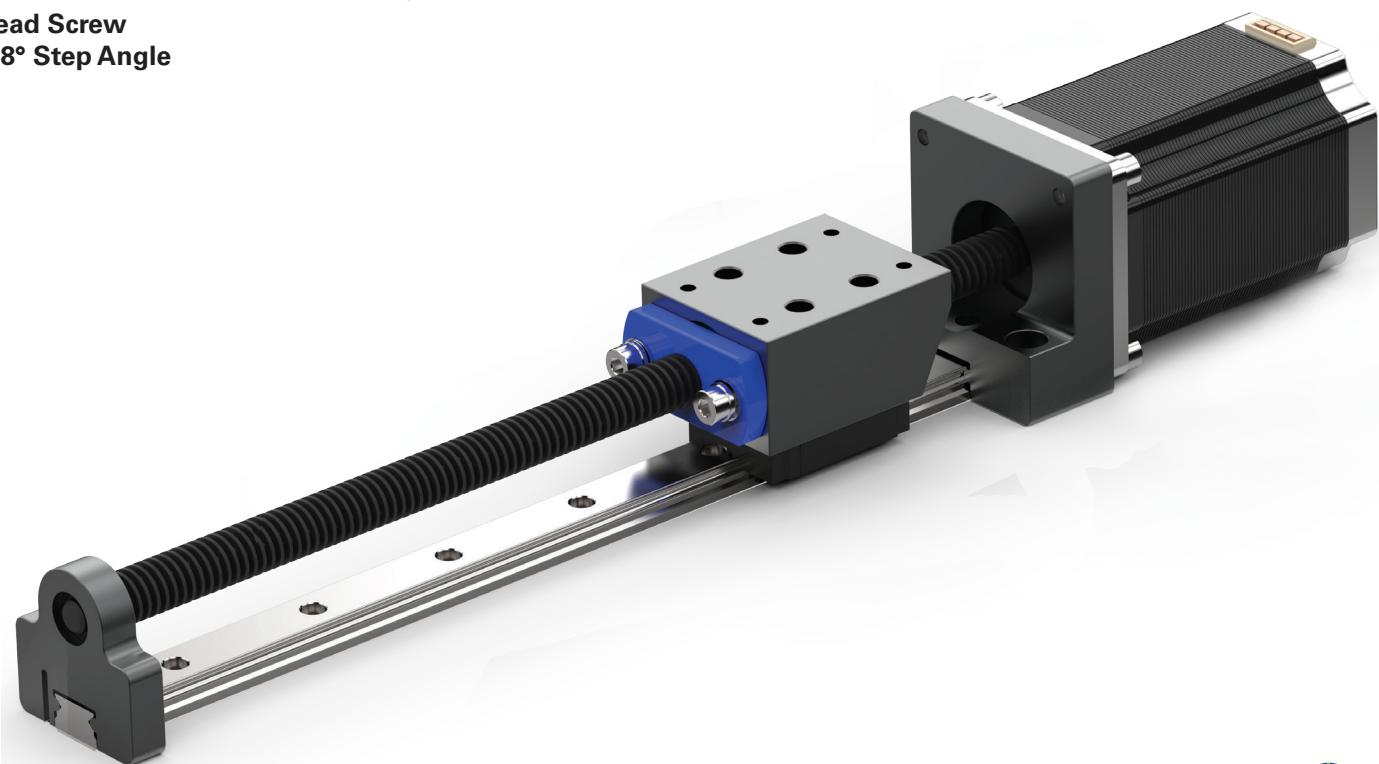

Motor Characteristics

Wiring	Rated Voltage (V)	Rated Current (A)	Resistance /Phase (Ω)	Inductance /Phase (mH)	Power Consumption (W)	Temperature Rise (° F)	Weight (oz)	Insulation Resistance (MΩ)
Bi-Polar	3.25	3.32	0.98	1.33	14	167	12.42	20
	5	2.16	2.31	6.6				
	12	0.9	13.33	45.1				

Available Lead Screws

Model	Screw Diameter	Lead	Pitch	Travel Per Step	L Minimum (in)	L Maximum (in)
PRA-23-098	0.500	0.0980	0.0980	0.00049	Travel + 3.7	24 <i>Longer custom order lengths available. Contact sales for details.</i>
PRA-23-100	0.500	0.1000	0.1000	0.00050		
PRA-23-250	0.500	0.2500	0.1250	0.00125		
PRA-23-200	0.500	0.2000	0.1000	0.00100		
PRA-23-500	0.500	0.5000	0.1000	0.00250		
PRA-23-800	0.500	0.8000	0.1000	0.00400		
PRA-23-999	0.500	1.0000	0.1250	0.00500		

Wiring Diagram

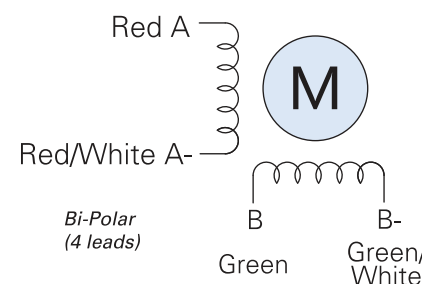

NEMA 23 - Double Stack Specifications

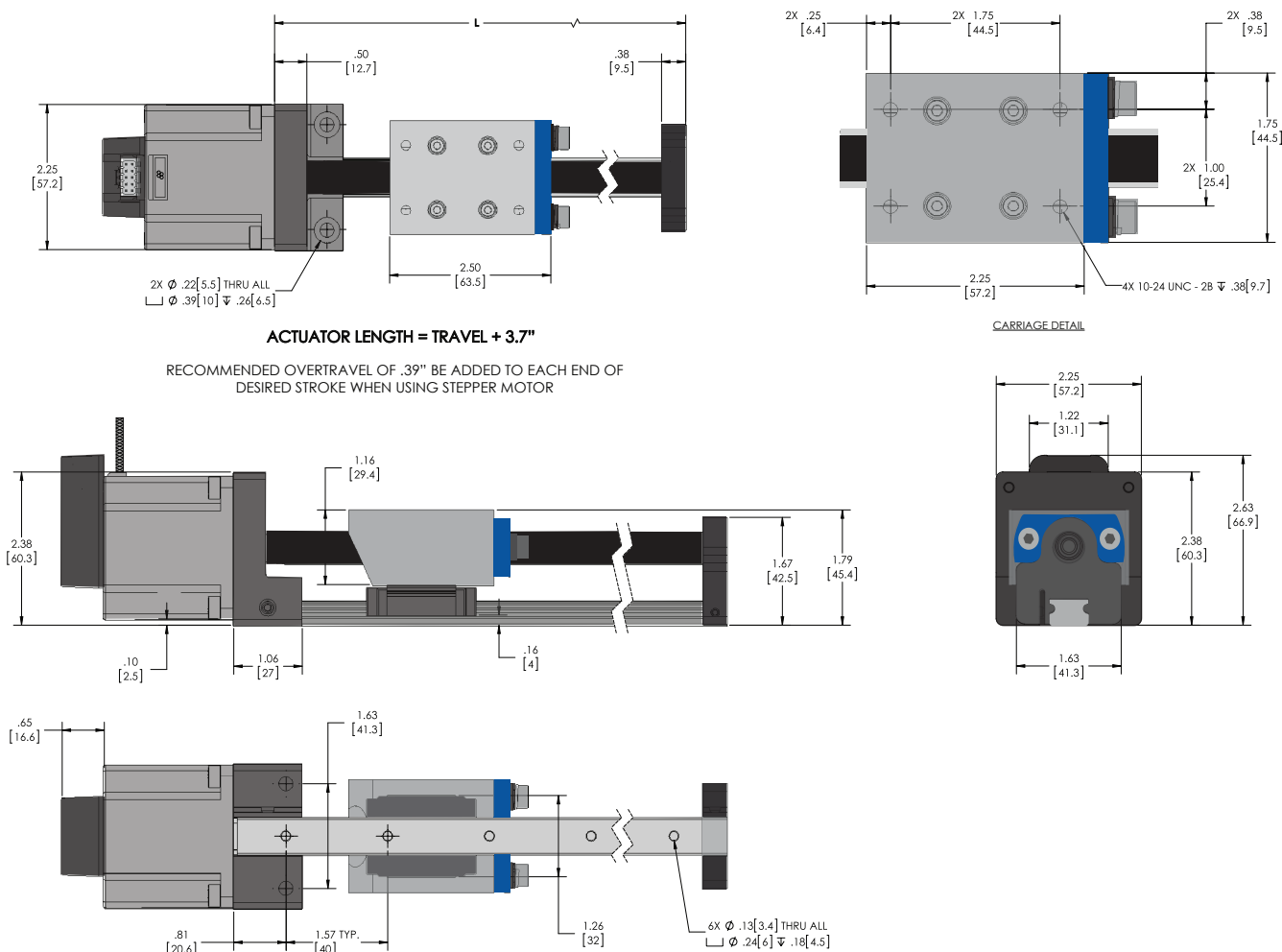

Force/Speed Charts

Force vs. Speed

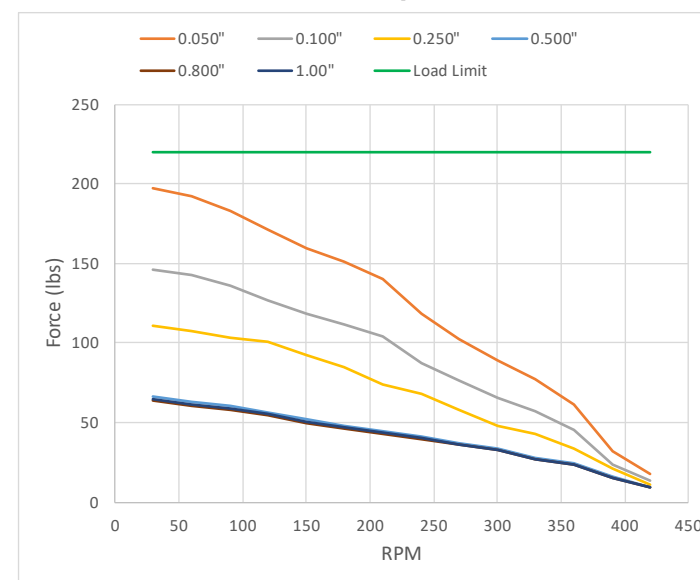

Force vs. Linear Velocity

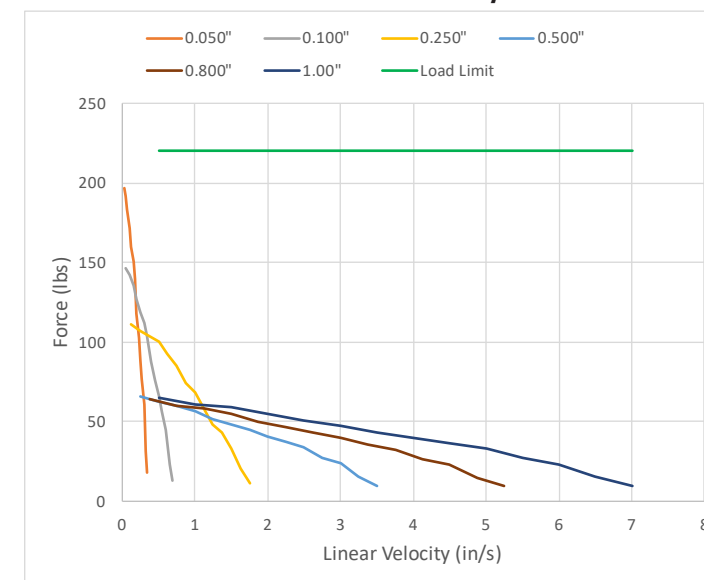

CARRIAGE LOADS

PRA-8

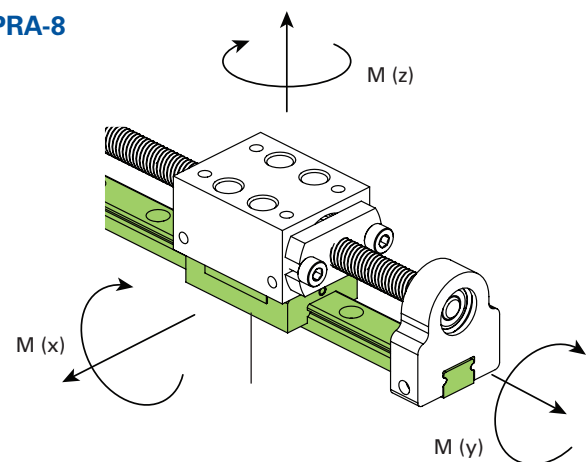

PRA-11,17,23

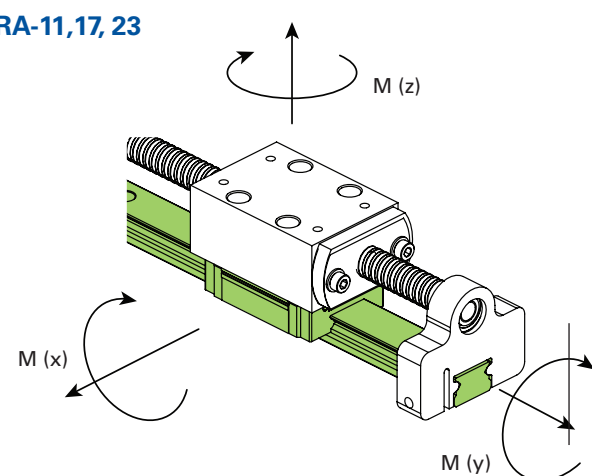

	X	Y	Z	Normal Load
PRA-8	$M_x = 29 \text{ in./lbs.}$	$M_y = 46 \text{ in./lbs.}$	$M_z = 29 \text{ in./lbs.}$	$F_z = 200 \text{ lbs. dynamic}$ $F_z = 323.7 \text{ lbs. static}$
PRA-11, 17, 23	$M_x = 239 \text{ in./lbs.}$	$M_y = 386 \text{ in./lbs.}$	$M_z = 239 \text{ in./lbs.}$	$F_z = 856.5 \text{ lbs. dynamic}$ $F_z = 1256.7 \text{ lbs. static}$

*The above loads are MAX values. Consult our Application Engineers for more information.

ENCODER OPTIONS

- Optical Rotary Encoders
- 32-5000 CPR available
- 128-20,000 pulses per revolution
- 2-channel quadrature TTL squarewave outputs
- 5-pin or 10-pin latching connector

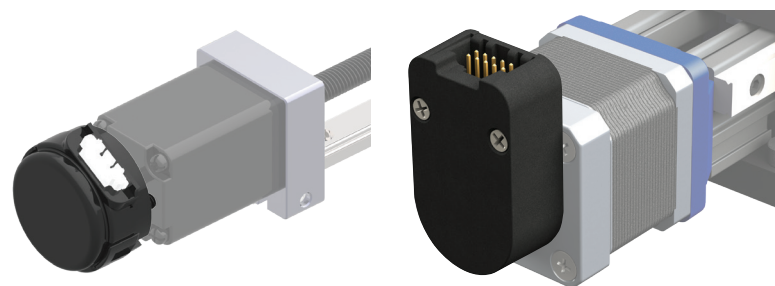

H10X™ PTFE COATING

- Extends nut life 8-10X
- Clean approved for food grade applications
- Resistant to solvents
- Clean-room approved
- Vacuum Rated Coating 10-6 Torr

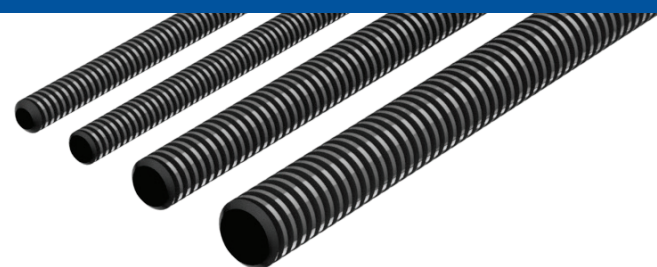

CUSTOM DESIGNS

NEMA 8 LINEAR ACTUATOR AND LINEAR POTENTIOMETER

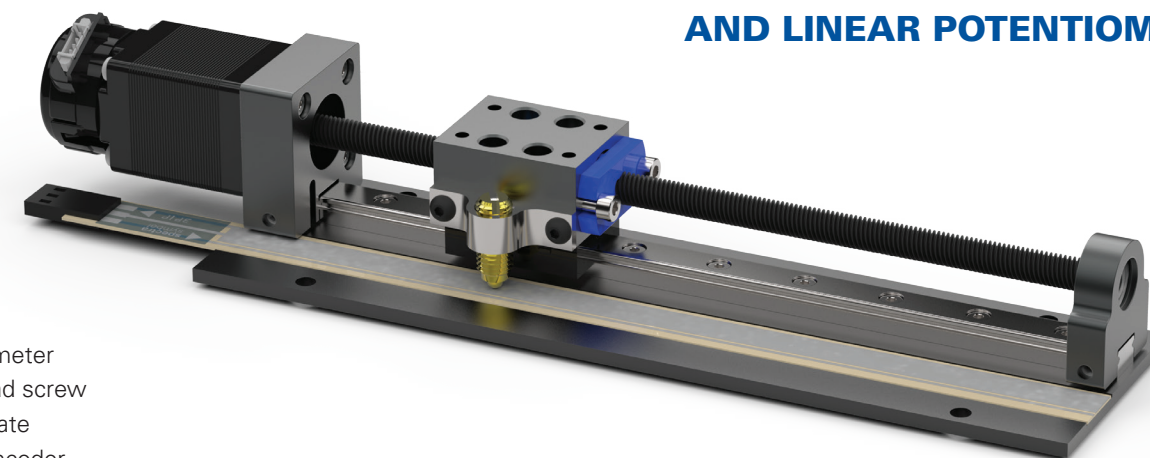

FEATURES

- Profile linear rail
- Linear potentiometer
- PTFE coated lead screw
- Custom base plate
- Optical rotary encoder

NEMA 11 LINEAR ACTUATOR AND OPTICAL ROTARY ENCODER

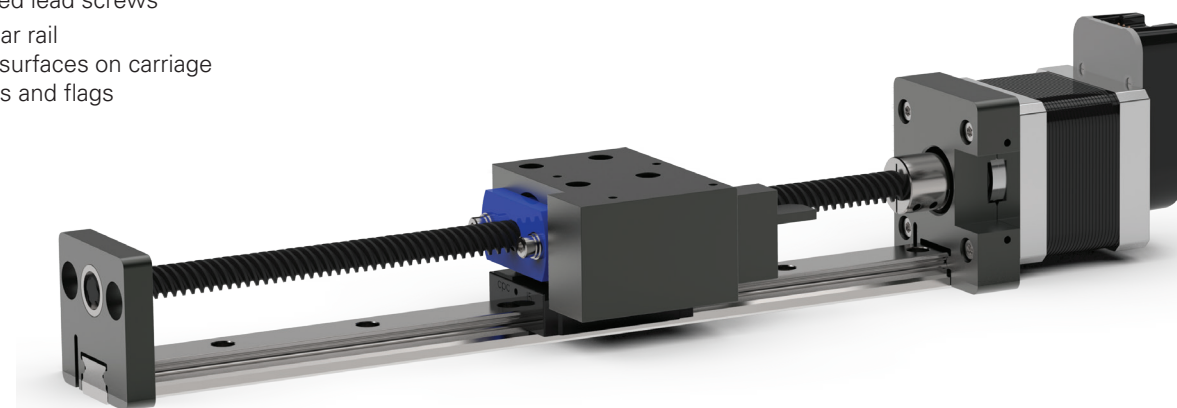

FEATURES

- Custom carriage
- PTFE coated lead screws
- Profile linear rail
- Mounting surfaces on carriage for sensors and flags
- Encoder

NEMA 17 CUSTOM LINEAR ACTUATOR

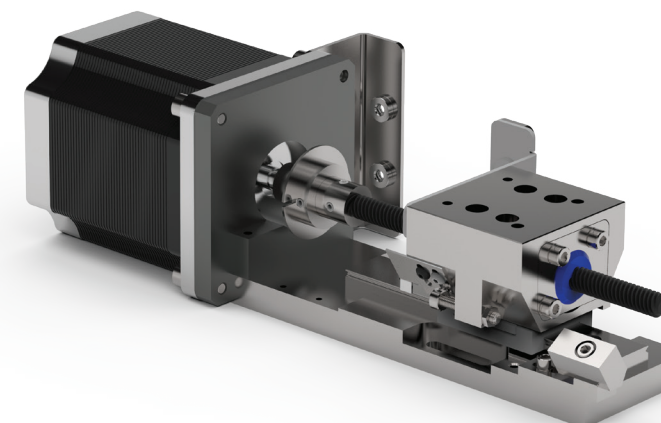

FEATURES

- Anti-backlash nut
- Clean room compatible
- Vacuum rated
- Mounting for flags and sensors

LINEAR MOTION APPLICATIONS

High Quality, Precision Linear Motion Solutions

- Hybrid Linear Actuator**
- NEMA 8, 11, 17, 23
 - Single and double stack
 - Optional optical encoders

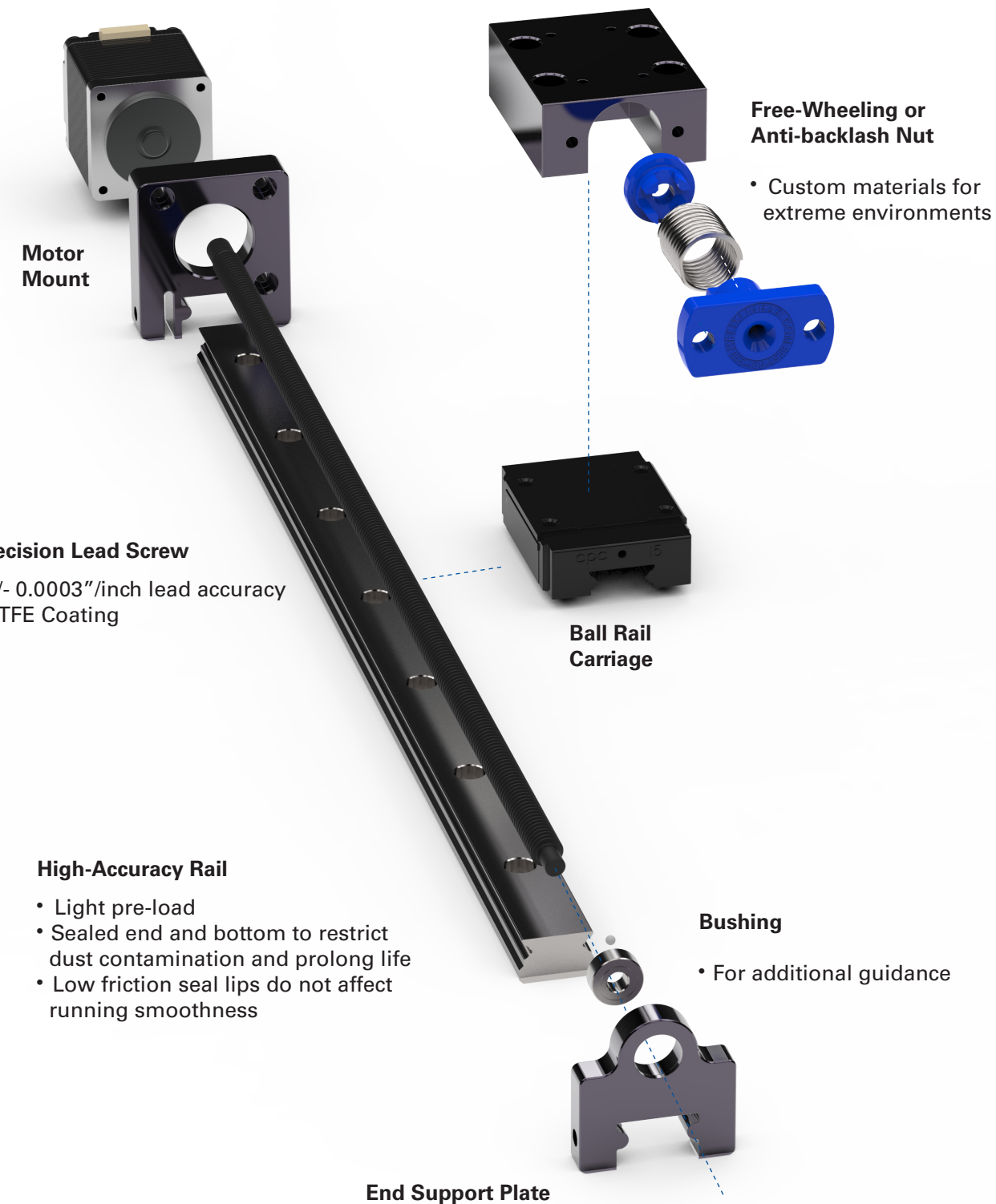

LIFE SCIENCES



- Auto samplers
- Syringe pumps
- Microscopes
- MRI scanners
- CT scanners
- Radiographic machines
- In-vitro diagnostics
- Genomics
- Blood gas chemistry

PRINTING & BINDING



- "Z" axis actuators
- Multi-axis gantries
- 3D printing
- Automation / Material handling
- Additive manufacturing (AD)
- Large format sign printing
- Digital offset printing process
- Folding and sealing equipment
- Thermal CTP systems

SECURITY - MILITARY



- Automated door locking systems
- Pan-tilt-zoom cameras
- Automated gates
- Tactical automated security cameras
- Missile fin actuation
- Tank sighting systems
- Drones and UAVs
- Torpedo fin actuation
- Guided munitions

SEMICONDUCTOR



- Burnishing stages
- Stacking systems
- Vision inspection machines
- X, Y, Z gantries
- Wafer elevators / Wafer handling
- Acoustic microscopes
- Ultrasonic imaging
- Tuning coils
- Vacuum chamber doors